

## Live Centers



### High Speed Steel – Main Line

MAIN-LINE: Reliable top of the range live center for CNC and conventional lathes, and grinding machines

- With over-pressure security through disc springs
- Body and spindle models: SM – Small body for light pieces and higher turning rate  
ST – Standard for normal loads  
SU – Super for heavy duty loads and low turning rates

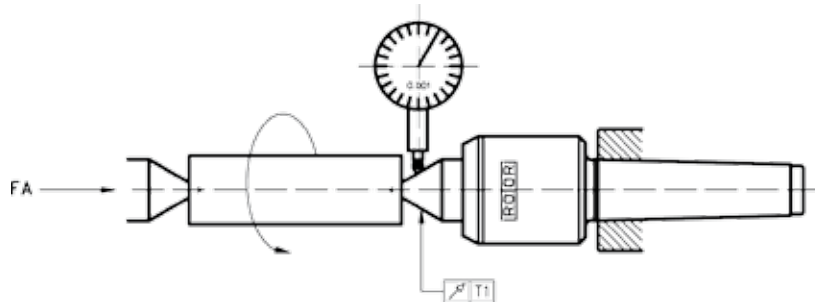

### Type N – Standard 60°

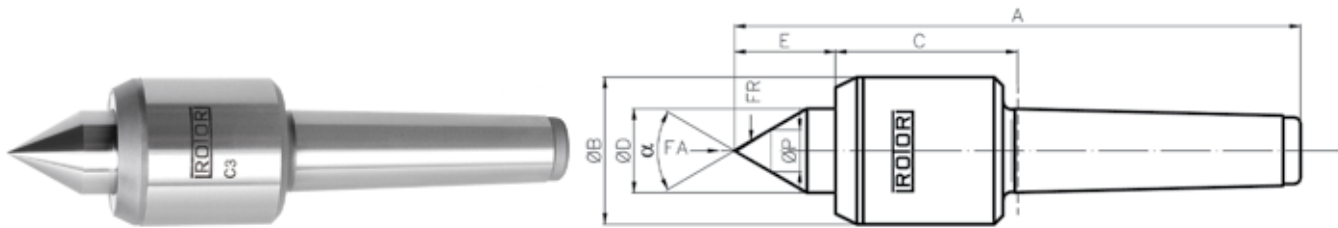

#### Accuracy of Mainline - Type N

Morse Taper	Type	FA daN min.	T1 mm max.	T1 inch max.
1-6 STD	N, V, L, A, K	20-50	0.005	0.0002
6 SUP, 7 SUP	N, A	100	0.008	0.0003

Morse Taper	Model	A (Inch)	B (Inch)	C (Inch)	D (Inch)	E (Inch)	ØP (Inch) C/T Only	Workpiece Maximum (lbs)	Maximum RPM	Code
1	1 STD.	4.41	1.10	1.54	0.47	0.63	0.28	220	8000	100101
2	2 STD.	5.16	1.34	1.57	0.63	0.87	0.28	484	7000	100102
2	2 SUP.	5.79	1.65	1.93	0.95	1.14	0.43	704	5800	100112
3	3 SM.	5.83	1.34	1.57	0.63	0.87	0.28	880	7000	100133
3	3 STD.	6.56	1.65	1.93	0.95	1.14	0.43	1120	5800	100103
3	3 SUP.	6.93	2.05	2.13	1.18	1.42	0.55	1540	4800	100113
4	4 SM.	7.32	1.65	1.93	0.95	1.14	0.43	1540	5800	100134
4	4 STD.	7.80	2.05	2.13	1.18	1.42	0.55	2420	4800	100104
4	4 SUP.	8.35	2.52	2.32	1.58	1.77	0.71	3960	4000	100114
5	5 SM.	8.94	2.13	2.13	1.18	1.42	0.55	3124	4500	100135
5	5 STD.	9.53	2.60	2.36	1.58	1.77	0.71	4620	4000	100105
5	5 SUP.	10.55	3.35	3.03	1.97	2.17	0.95	6600	2800	100115
6	6 STD.	12.67	3.39	3.07	1.97	2.17	0.71	8800	2800	100106
6	6 SUP.	13.98	4.96	4.32	2.36	2.56	0.95	13200	1500	100116
7	7 SUP.	19.06	5.67	5.51	3.15	3.11	1.20	31000	1200	100117

## Live Centers

High Speed Steel – Main Line



### Type V – Extended Point 60°

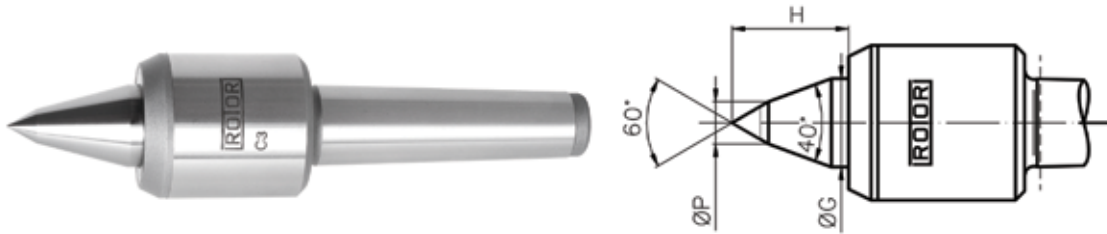

Morse Taper	Model	ØG (Inch)	H (Inch)	ØP (Inch)	Workpiece Maximum (lbs)	Maximum RPM	Code
1	1 STD.	0.47	0.79	0.26	190	8000	100151
2	2 STD.	0.63	1.02	0.35	390	7000	100152
2	2 SUP.	0.94	1.50	0.39	460	5800	100162
3	3 SM.	0.63	1.02	0.35	680	7000	100173
3	3 STD.	0.94	1.50	0.39	970	5800	100153
3	3 SUP.	1.18	1.89	0.55	1450	4800	100163
4	4 SM.	0.94	1.50	0.39	1150	5800	100174
4	4 STD.	1.18	1.89	0.55	1900	4800	100154
4	4 SUP.	1.57	2.52	0.59	2400	4000	100164
5	5 SM.	1.18	1.89	0.55	2300	4500	100175
5	5 STD.	1.57	2.52	0.59	3200	4000	100155
5	5 SUP.	1.97	3.15	0.71	5300	2800	100165
6	6 STD.	1.97	3.23	0.71	6800	2800	100156

### Type L – Slim Extended Point 60°



Morse Taper	Model	ØD (Inch)	E (Inch)	H (Inch)	ØP (Inch)	Code
2	2 STD.	0.63	1.14	0.47	0.23	100180
3	3 SM	0.63	1.14	0.47	0.23	100181
3	3 STD.	0.94	1.65	0.63	0.31	100182
4	4 SM	0.94	1.65	0.63	0.31	100183
4	4 STD.	1.18	2.01	0.75	0.39	100184
5	5 SM	1.18	2.01	0.75	0.39	100185
5	5 STD.	1.57	2.56	0.87	0.46	100186

## Live Centers



### High Speed Steel – Speed-Line

SPEED-LINE: Precise live centers for high turning rates

- Suitable for CNC/manual turning and grinding machines
- Optimal protection against splash and dirt
- Ground tapers conform to DIN 228 AT3
- Through-hardened 60° point
- Mounted with an angular contact ball bearing and deep grooved ball bearing

#### Type EV – 60°

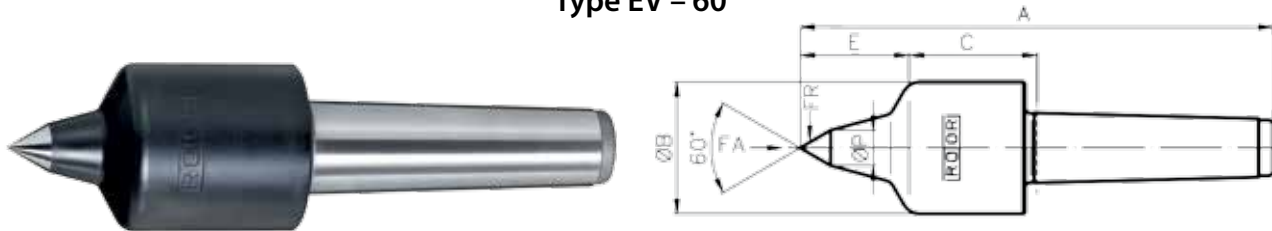

#### Accuracy of Speed-Line - Type EV

Morse Taper	T1 mm Maximum	T1 inch Maximum
2 ST, 2 SU, 3 ST	0.002	0.0001
3 SU, 4 ST, 4 SU, 5 ST	0.002	0.0001
5 SU, 6 ST	0.004	0.0002

Morse Taper	Model	A (mm)	ØB (mm)	C (mm)	E (mm)	ØP (mm)	Workpiece Maximum (kgs)	FR Maximum daN	FA Maximum daN	Maximum RPM	Code
2	2 ST	134	38	38	31	8	180	90	90	13,500	826213
2	2 SU	147	45	44	37	12	260	130	115	11,000	826214
3	3 ST	164	45	45	37	12	260	130	115	11,000	826215
3	3 SU	183	55	61	39	16	440	220	260	8,500	826216
4	4 ST	206	55	62	39	16	440	220	260	8,500	826217
4	4 SU	233	70	68	50	20	670	335	440	6,700	826218
5	5 ST	250	70	70	50	20	670	335	440	6,700	826219
5	5 SU	268	82	84	53	20	950	475	925	5,300	826220
6	6 ST	322	82	84	53	20	950	475	925	5,300	826221



## Live Centers

High Speed Steel – Main Line

### Type A – Point Nose Taper for Mounting Cones



Morse Taper	Model	Øl (Inch)	L1 (Inch)	L2 (Inch)	Code	Morse Taper	Model	Øl (Inch)	L1 (Inch)	L2 (Inch)	Code
1	1 STD.	0.44	0.59	0.75	100201	5	5 STD.	1.35	1.38	1.57	100205
2	2 SUP.	0.88	1.18	1.38	100212	5	5 SUP.	1.35	1.38	1.65	100215
3	3 STD.	0.88	1.18	1.38	100203	6	6 STD.	1.35	1.38	1.65	100206
3	3 SUP.	0.88	1.18	1.42	100213	6	6 SUP.	1.87	1.89	2.13	100216
4	4 STD.	0.88	1.18	1.42	100204	7	7 SUP.	1.87	1.89	2.16	100217
4	4 SUP.	1.35	1.38	1.57	100214						

### Model D – Cones for Type A Point Nose Tapers

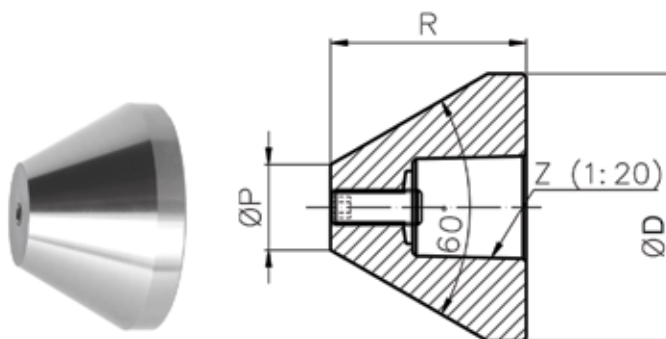

ØD (Inch)	ØP (Inch)	R (Inch)	S (Inch)	Code	ØD (Inch)	ØP (Inch)	R (Inch)	S (Inch)	Code
2.00	0.63	1.58	M6	100421	8.00	4.33	3.54	M12	100481
3.00	0.90	2.16	M10	100432	4.75	1.77	2.95	M12	100451
4.00	1.77	2.36	M10	100441	6.00	2.76	3.15	M12	100462
6.00	2.75	3.15	M10	100452	8.00	4.33	3.54	M12	100482
4.00	1.77	2.36	M12	100442					
6.00	2.76	3.15	M12	100461					

## Live Centers

High Speed Steel – Main Line



### Type DA-N – Standard 60° with Pressure Indicator

APPLICATION: A pressure indicator with different colour bands permits rapid setting and monitoring of the optimum pressure. Length tolerances and different centre bores are compensated through a travel stroke at fixed positions. Correspondingly light work pieces can be clamped very finely.

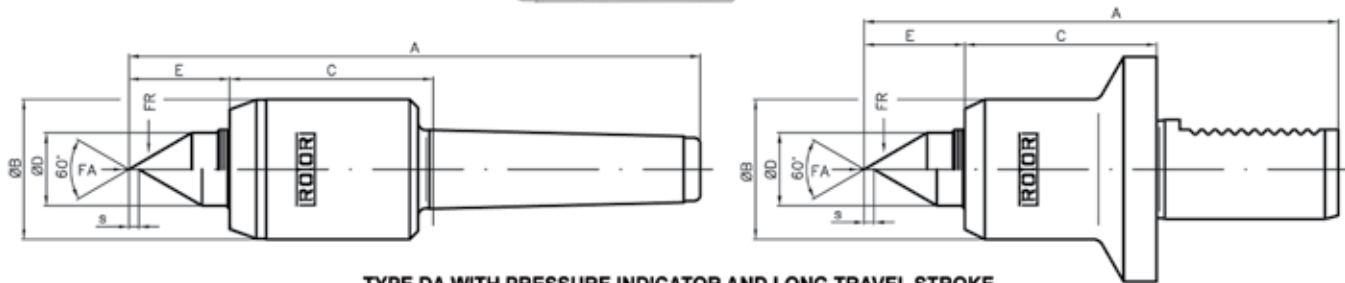

TYPE DA WITH PRESSURE INDICATOR AND LONG TRAVEL STROKE

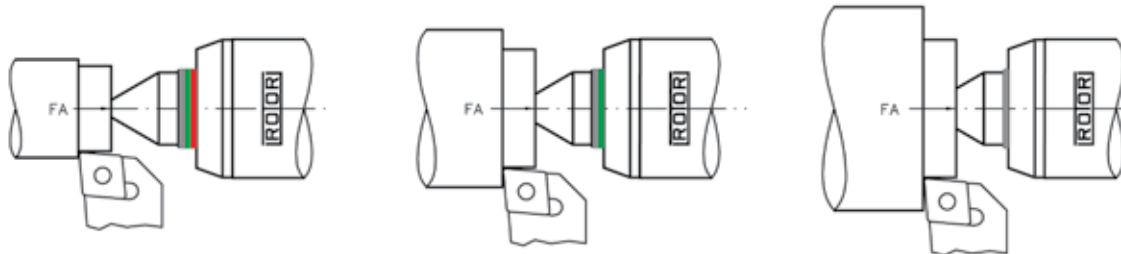

Light workpiece and  
low stock removal  
= low pressure

Medium workpiece and  
moderate stock removal  
= medium pressure

Heavy workpiece and  
heavy stock removal  
= high pressure

Morse Taper	Model	A (Inch)	ØB (Inch)	C (Inch)	ØD (Inch)	E (Inch)	S (Inch)	Workpiece Maximum (kgs)	Maximum RPM	Code
2	2 STD.	136	34	53	14	19	2.7	190	7000	100090
3	3 STD.	173	42	62	22	31	3.0	440	5800	100091
4	4 STD.	209	53	72	28	33	4.3	900	4800	100092
5	5 STD.	259	64	88	38	42	5.2	1850	4000	100093
-	cyl. Ø20x40	108	34	48	14	19	2.7	190	7000	826375
-	cyl. Ø25x50	139	42	58	22	31	3.0	190	5800	826376
-	cyl. Ø1x2	139	42	58	22	31	3.0	440	5800	826377
-	cyl. Ø32x63	165	53	68	28	33	4.3	900	4800	826378
-	VDI20	108	34	48	14	19	2.7	190	7000	826379
-	VDI30	144	42	58	22	31	3.0	440	5800	826380
-	VDI40	165	53	68	28	34	4.3	900	4800	826381
-	VDI50	201	64	81	38	42	5.2	1850	4000	826382

## Live Centers

### Bull Nose

- Designed for turning pipes, tubes, and parts with extra-large center holes
- $\pm 0.00005$ " total indicator runout guaranteed
- Two matched angular contact bearings provide good thrust and radial load ratings
- Head diameter is  $1/8$ " over nominal size, enabling these centers to cover a wider range of work pieces
- Head and shank are hardened for strength and durability
- Pipe head models also available

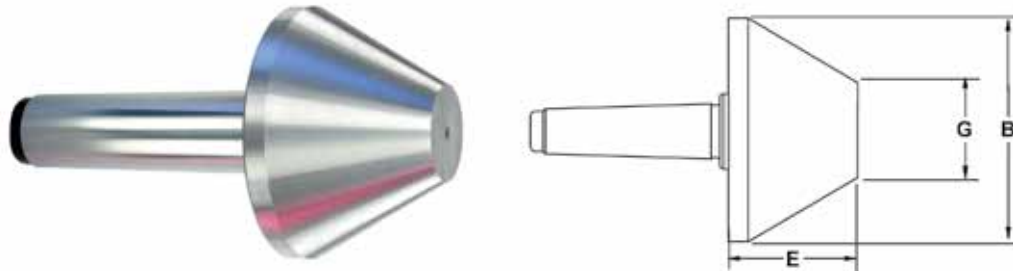

Morse Taper	B (Inch)	E (Inch)	G (Inch)	Maximum RPM	Weight (lbs)	Thrust Load	Code
3	3-1/8	2-1/2	1	5000	615	1780	826341
3	4-1/8	3	1-1/4	4500	860	2550	826342
4	4-1/8	3	1-1/4	4500	860	2550	826343
5	4-1/8	3	1-1/4	4500	860	2550	826344
4	5-1/8	3-3/16	2	4000	1145	3450	826345
5	5-1/8	3-3/16	2	4000	1145	3450	826346
5	6-1/8	3-5/8	2-1/2	3500	1450	4500	826347
6	6-1/8	3-5/8	2-1/2	3500	1450	4500	826348

## Live Centers

### Bull Nose

- Bull Nose - CR-MO steel hardened to RC60
- Combination of roller and ball bearings

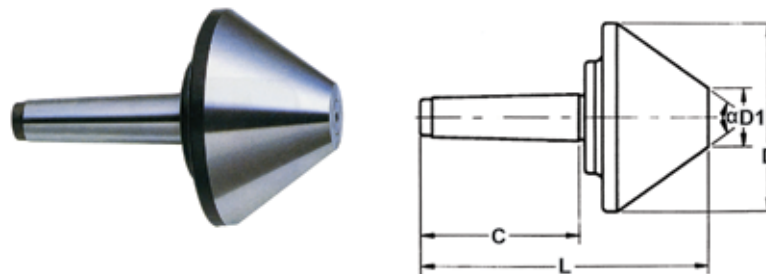

Morse Taper	D Large Diameter (Inch)	D1 Small Diameter (Inch)	L (Inch)	C (Inch)	Included Angle	Load Weight (lbs)	Maximum RPM	Weight (lbs)	Code
2	2.50	0.50	5.50	3.30	60°	450	4000	2	120132
2	3.00	0.75	5.79	3.30	60°	450	4000	2	826359
3	3.00	0.75	6.30	3.78	60°	450	4000	2	826360
3	4.00	1.25	6.30	3.78	70°	800	3300	3	120133
3	5.00	1.38	7.00	3.78	70°	1100	3000	6	826361
4	4.00	1.25	7.08	4.52	70°	1100	3000	7	826362
4	5.00	1.38	7.75	4.52	70°	1400	2000	10	826363
4	6.00	2.00	8.00	4.52	70°	1760	1900	17	120134
5	5.00	1.38	9.00	5.86	70°	1430	2000	13	826364
5	6.00	2.00	9.25	5.86	70°	1760	1900	19	826365
5	8.00	2.00	10.35	5.86	75°	3520	1500	40	120135

## Live Centers



### Value-Turn

- A sturdy low-cost center designed for general medium-duty turning applications
- $\pm 0.00005$ " total indicator runout guaranteed
- Precision three-bearing design enables the Royal Value-Turn to achieve both high RPM's and solid load ratings
- Head is hardened for strength and durability

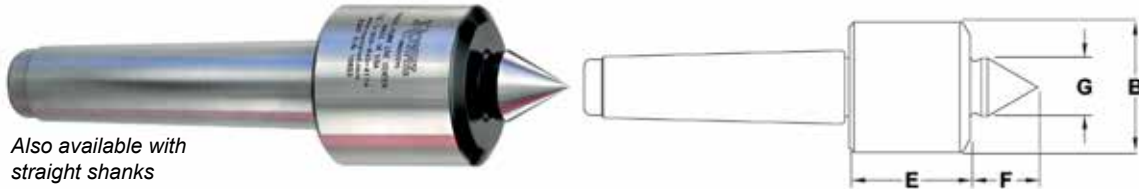

Morse Taper	B (Inch)	E (Inch)	F (Inch)	G (Inch)	*Maximum Suggested RPM	Weight of Workpiece (lbs)	Thrust Load (lbs)	Code
2	1-11/16	1-9/16	7/8	3/4	5000	390	3730	826258
3	1-11/16	1-9/16	7/8	3/4	5000	390	3730	826259
4	2-7/16	2-1/32	1-3/16	1-1/8	4500	750	4990	826260
5	2-7/16	2-1/32	1-3/16	1-1/8	4500	750	4990	826261

\*Maximum recommended operating limit. Operating above the speed could result in heat build-up and accelerated bearing wear.

### High Speed Precision

- A true high-speed live center — up to 12,000 rpm
- Lubricated with lightweight spindle oil instead of grease for reduced turning resistance and lower operating temperatures
- $\pm 0.00005$ " total indicator runout guaranteed
- Three precision angular contact bearings are secured to the point with a locknut to form a rigid, preloaded assembly
- The point extends into the body where it is supported by a needle roller bearing, which further increases rigidity, reduces point deflection, and dampens vibration
- Low profile head provides excellent tool clearance
- Body and point are hardened for strength and durability

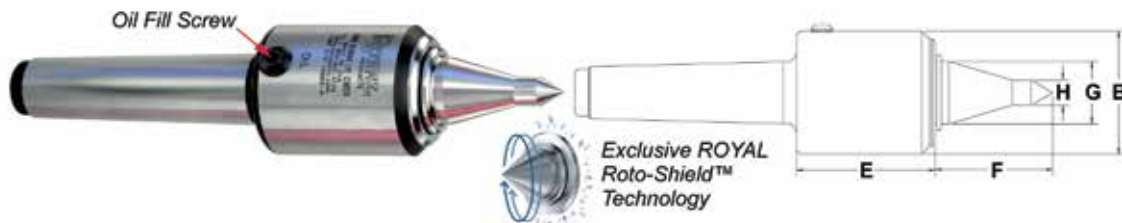

Morse Taper	B (Inch)	E (Inch)	F (Inch)	G (Inch)	H (Inch)	Maximum RPM	Weight (lbs)	Thrust Load	Code
3	1-3/4	2-3/64	1-3/4	7/8	3/8	12000	180	650	826262
4	2-1/2	2-11/16	2-11/32	1-1/4	1/2	12000	525	1380	826263
5	2-1/2	2-11/16	2-11/32	1-1/4	1/2	12000	525	1380	826264



## Live Centers

### Super Quad Extra Heavy-Duty

- Designed for very large, heavy parts — up to 12,000 lbs
- $\pm 0.00005$ " total indicator runout guaranteed
- Three huge angular contact bearings and a beefy needle roller bearing combine to form a very strong, rigid assembly
- Large, sturdy point and thick-walled head ensure minimal deflection under load
- Body and point are hardened for strength and durability



Morse Taper	B (Inch)	E (Inch)	F (Inch)	G (Inch)	Maximum RPM	Weight (lbs)	Thrust Load	Code
4	3-11/16	3-5/16	1-3/4	1-5/8	4000	3325	4800	826265
5	4-15/16	4-5/16	2-7/16	2-3/8	3000	10650	13220	826266
6	4-15/16	4-5/16	2-7/16	2-3/8	3000	10650	13220	826267
6	6-15/16	5-11/16	3-7/32	3-1/8	2500	12130	25920	826268

### Heavy-Duty Spindle Type – Standard Point & CNC Point

- An excellent heavy-duty live center designed to handle most turning applications
- $\pm 0.00005$ " total indicator runout guaranteed
- Heavy-duty precision bearings provide exceptional thrust and radial load capacities
- The substantial point extends into the shank where it is supported by a large needle bearing for increased strength and rigidity
- Body and point are hardened for strength and durability
- On the CNC model, the extended point provides great tool clearance

#### Standard Point



Morse Taper	B (Inch)	E (Inch)	F (Inch)	G (Inch)	Maximum RPM	Weight (lbs)	Thrust Load	Code
2	1-3/4	1-7/16	1-1/32	7/8	6000	725	2360	826270
3	2-3/8	1-3/4	1-1/4	1	5000	970	3900	826271
4	2-11/16	1-31/32	1-1/2	1-1/4	4500	1720	4050	826272
5	3-1/2	2-13/16	1-7/8	1-1/2	3500	3260	5700	826273
6	4	3-5/32	2-5/16	2	3500	4080	6000	826274



## Live Centers



### Heavy-Duty Spindle Type – Standard Point & CNC Point *(continued)*

#### CNC Point for Extra Tool Clearance



Morse Taper	B (Inch)	E (Inch)	F (Inch)	G (Inch)	H (Inch)	Maximum RPM	Weight (lbs)	Thrust Load	Code
2	1-3/4	1-7/16	1-3/8	7/8	3/8	6000	375	2360	826275
3	2-3/8	1-3/4	1-7/8	1	3/8	5000	740	3900	826276
4	2-11/16	1-31/32	2-7/32	1-1/4	1/2	4500	1120	4050	826277
5	3-1/2	2-13/16	2-5/8	1-1/2	1/2	3500	1930	5700	826278

### High Precision Quad-Bearing – Standard Point & CNC Point

- Great for grinding and tight tolerance turning
- ±0.00005" total indicator runout guaranteed
- Three precision angular contact bearings are secured to the point with a locknut to form a rigid, preloaded assembly
- The point extends into the body where it is supported by a needle roller bearing, which further increases rigidity, reduces point deflection, and dampens vibration
- Low profile head provides excellent tool clearance
- Body and point are hardened for strength and durability

#### Standard Point



Morse Taper	B (Inch)	E (Inch)	F (Inch)	G (Inch)	Maximum RPM	Weight (lbs)	Thrust Load	Code
3	1-3/4	2-1/8	1-1/16	7/8	6000	885	1270	826279
4	2-1/2	2-3/4	1-1/2	1-1/4	5000	2240	2150	826280
5	2-1/2	2-3/4	1-1/2	1-1/4	5000	2240	2150	826281
* 5 HD	3-7/8	3-7/8	2-5/16	2	3000	5240	5300	826282
* 6 HD	3-7/8	3-7/8	2-5/16	2	3000	5240	5300	826283

\*Heavy Duty

## Live Centers



### High Precision Quad-Bearing – Standard Point & CNC Point (continued)

#### CNC Point for Extra Tool Clearance



Morse Taper	B (Inch)	E (Inch)	F (Inch)	G (Inch)	H (Inch)	Maximum RPM	Weight (lbs)	Thrust Load	Code
3	1-3/4	2-1/8	1-3/4	7/8	3/8	6000	465	1270	826284
4	2-1/2	2-25/32	2-11/32	1-1/4	1/2	5000	1230	2150	826285
5	2-1/2	2-25/32	2-11/32	1-1/4	1/2	5000	1230	2150	826286

#### Spring Type – Standard Point

- Unique spring-loaded point compensates for work piece thermal expansion
- $\pm 0.00005$ " total indicator runout guaranteed
- Low-profile design provides outstanding tool clearance
- Heavy disc springs ensure that the point remains seated in the work piece
- Point and shank are hardened for strength and durability

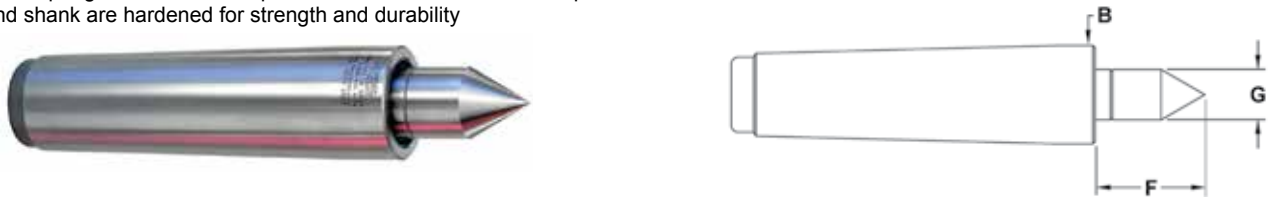

Morse Taper	B (Inch)	F (Inch)	G (Inch)	Spring Travel (Inch)	Maximum RPM	Weight (lbs)	Thrust Load	Code
2	0.700	7/8	3/8	0.11	5000	540	150	826349
3	0.938	1-5/32	9/16	0.14	5000	940	315	826350
4	1.231	1-3/8	5/8	0.18	4500	1400	435	826351
5	1.748	2	1-3/32	0.19	4500	2340	785	826352

#### Versa-Turn

- A great multi-purpose live center designed to handle most common turning jobs - Extended point provides good tool clearance - Bull head is great for tubes and parts with large center holes
- $\pm 0.00005$ " total indicator runout guaranteed on both sections of rotating point
- The Royal Versa-Turn is extremely free turning excellent for thin parts that cannot take high thrust loads
- Head and shank are hardened for strength and durability



Morse Taper	B (Inch)	E (Inch)	F (Inch)	G (Inch)	Maximum RPM	Weight (lbs)	Thrust Load	Code
2	2-1/8	2-7/32	3/4	1/2	5000	330	2160	826353
3	2-1/8	2-7/32	3/4	1/2	5000	330	2160	826354
* 3 HD	2-1/2	2-5/8	15/16	5/8	4000	685	5000	826355
4	2-1/2	2-5/8	15/16	5/8	4000	685	5000	826356
* 4 HD	3-3/8	3-1/8	1-1/8	3/4	3500	1165	5700	826357
5	3-3/8	3-1/8	1-1/8	3/4	3500	1165	5700	826358

\*Heavy Duty

## Live Center Sets 7 Interchangeable Points

- Construction consists of double rows of ball bearings and thrust bearings
- Ground for higher accuracy
- 60° point

### SET INCLUDES:

- 5 male centers
- 1 female center
- 1 bull center
- 1 extractor
- Supplied In fitted storage case

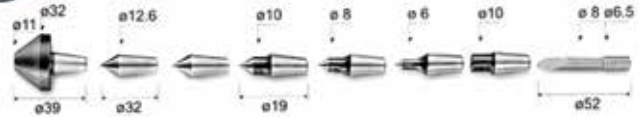
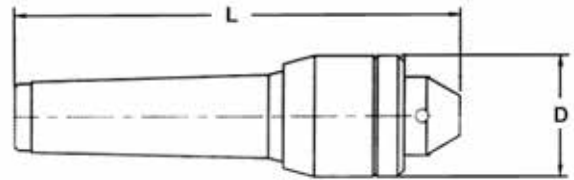

Morse Taper	D Outside Diameter (Inch)	L Length (Inch)	Code
2	1.57	5.20	120122
3	1.81	6.22	120123
4	1.81	7.08	120124
5	2.50	9.21	120125

## Dead Centers

### High Speed Steel & Carbide Tipped



Morse Taper	HSS	Carbide Tipped
	Code	Code
1	125101	125111
2	125102	125112
3	125103	125113
4	125104	125114
5	125105	125115
6	125106	125116

## Dead Centers with Nut

### Alloy Steel & Carbide Tipped

- +/-0.0001" total indicator runout
- These dead centers are designed for use wherever high accuracies are required
- Case hardened to 61-63 RC
- Centers supplied with nuts

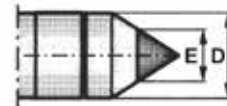
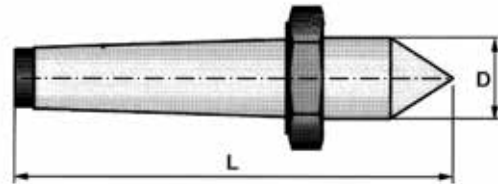

Morse Taper	L (Inch)	D (Inch)	E (Inch)	Weight (lbs)	Alloy Steel	Carbide Tipped
					Code	Code
1	3.54	0.48	0.28	0.22	826323	826329
2	4.41	0.71	0.28	0.55	826324	826330
3	5.43	0.95	0.43	1.10	826325	826331
4	6.89	1.24	0.55	2.43	826326	826332
5	8.54	1.76	0.71	5.73	826327	826333
6	11.42	2.51	0.71	14.55	826328	826334

## Dead Centers with Nut Alloy Steel & Carbide Tipped (continued)



### Spare Nuts



Thread Reference	For Alloy Steel Model	For Carbide Tipped Model	Code
M16 x 1.5	826323	826329	826335
M22 x 1.5	826324	826330	826336
M27 x 1.5	826325	826331	826337
M36 x 1.5	826326	826332	826338
M68 x 1.5	826328	826334	826340

## Lathe Chuck Technical Information Determining Proper Spindle Nose Type & Size



NOTE: Bison chucks meet all requirements of ASA Standard B5.9-1960. For spindle nose accuracy (T.I.R.)

### Selecting the Chuck Mount

- Choose from the types shown below
- For the short taper spindle noses Type A, D and C (DIN) measure the pilot diameter and length (sizes B and C), bolt circle diameter (size F1 and F2) and diameter of the holes (size E1 and E2). In the case of Type A mount check the number of bolt circles (one for A2 mount or two for A1 mount). All chucks with A1 mount can be installed on A1 spindle nose only. All chucks with A2 mount can be installed on A1 or A2 spindle noses.
- For the long taper spindle noses Type L, check pilot diameter, length and thread size (size A, C and B)
- For the threaded spindle noses, check the thread diameter, number of threads per inch and length (sizes A and E), pilot diameter and length (sizes B and D), plus overall length (size F1)

### Spindle Type A1 & A2

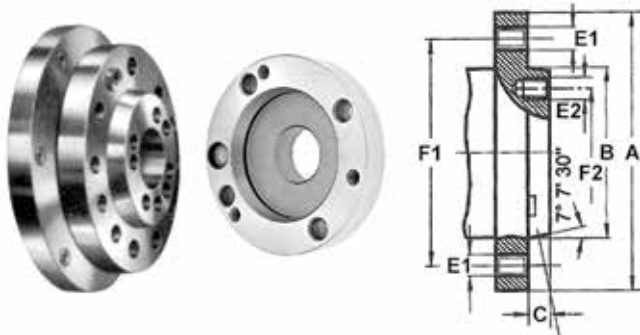

Spindle Nose	F1	F2	B	C Maximum	Thread E1=E2 UNC-3B
A4	3.250	-	2.5005 + 0.0005	0.4375	7/16 - 14
A5	4.125	2.4374	3.2505 + 0.0005	0.5625	7/16 - 14
A6	5.250	3.2500	4.1880 + 0.0005	0.6250	1/2 - 13
A8	6.750	4.3750	5.5007 + 0.0005	0.6875	5/8 - 11
A11	9.250	6.5000	7.7507 + 0.0005	0.7500	3/4 - 10
A15	13.000	9.7500	11.2510 + 0.0010	0.8125	7/8 - 9
A20	18.250	14.5000	16.2510 + 0.0010	0.8750	1 - 6

TYPE A1 is exactly as shown with tapped holes in both inner and outer bolt circles.  
TYPE A2 is same as shown except omit holes in inner bolt circle.

### Spindle Type D1 – Camlock

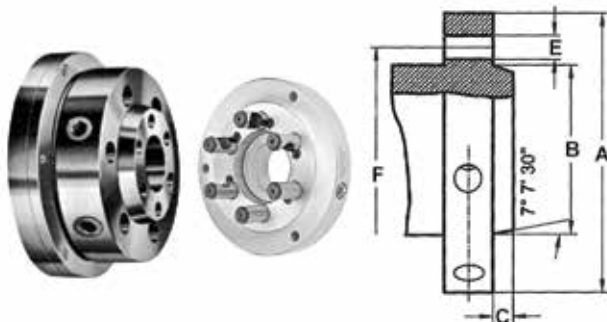

Spindle Nose	A	F	B	C Maximum	E	No. of Holes
D1-3	3.622	2.7820	2.1250 + 0.00025	7/16	0.5938	3
D1-4	4.606	3.2500	2.5005 + 0.00050	7/16	0.6562	3
D1-5	5.748	4.1250	3.2505 + 0.00050	1/2	0.8750	6
D1-6	7.126	5.2500	4.1880 + 0.00050	9/16	1.0000	6
D1-8	8.858	6.7500	5.5007 + 0.00050	5/8	1.1250	6
D1-11	11.732	9.2520	7.7507 + 0.00050	11/16	1.2500	6
D1-15	15.866	13.0000	11.2510 + 0.0010	3/4	1.3750	6

NOTE: Camlock stud length is adjustable to suit spindle cam

## Lathe Chuck Technical Information

### Determining Proper Spindle Nose Type & Size *(continued)*



### Threaded Spindle



A Spindle Nose	B	F1	D	E
1 - 10 UNS-2B	1.0150	1.5000	0.4375	1.0000
1-1/2 - 8 UN-2B	1.5150	1.5000	0.4375	1.0000
2-3/16 - 10 UN-2B	2.2025	1.7500	0.5625	1.1250
2-1/4 - 8 UN-2B	2.2600	1.7500	0.5625	1.1250
2-3/16 - 6 UN-2B	2.2025	1.7500	0.5625	1.1250
2-3/4 - 8 UN-2B	2.7600	2.0625	0.6875	1.3125

### Spindle Type C – DIN Standard 55027



Spindle Nose	F	B	C Maximum	E	No. of Holes
C4	3.2500	2.50050	0.4331	0.83	3
C5	4.1250	3.25050	0.5118	0.83	4
C6	5.2500	4.18800	0.5512	0.91	4
C8	6.7500	5.50075	0.6299	1.14	4
C11	9.2520	7.75075	0.7087	1.42	6

This spindle nose is provided with a short tapered flange like the American spindle noses A and D. Spindle flange has a number of mounting holes (3, 4 or 6) into which the lock studs of the chuck can be inserted and locked.

### Spindle Type L – Long Taper Key Drive

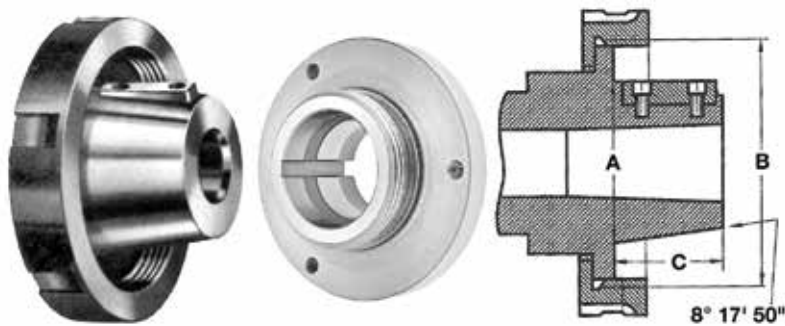

Spindle Nose	B Thread	C	A	Key
L00	3-3/4 - 6	2	2.750	3/8 x 3/8 x 1-1/2
L0	4-1/2 - 6	2-3/8	3.250	3/8 x 3/8 x 1-3/4
L1	6 - 6	2-7/8	4.125	5/8 x 5/8 x 2-3/8
L2	7-3/4 - 5	3-3/8	5.250	3/4 x 3/4 x 2-7/8
L3	10-3/8 - 4	3-7/8	6.500	1 x 1 x 3-1/4

## Lathe Chuck Grease



- 16 oz. can
- For manual and power chucks, fasteners, press fits, wear-in guides and ways

Code

355326

## Universal Lathe Chucks



### Semi-Steel Body – 3-Jaw Self-Centering

#### 2 Pc. Hard Reversible Jaws

- Semi-steel body
- 3 pinion design
- Plain back
- Backplates required

#### Standard Accessories:

- 1 set of hard master jaws
- 1 set of hard top reversible jaws
- 1 wrench
- 1 set of mounting bolts
- 2 hex keys
- Eye bolts for chuck sizes 15.75" and larger

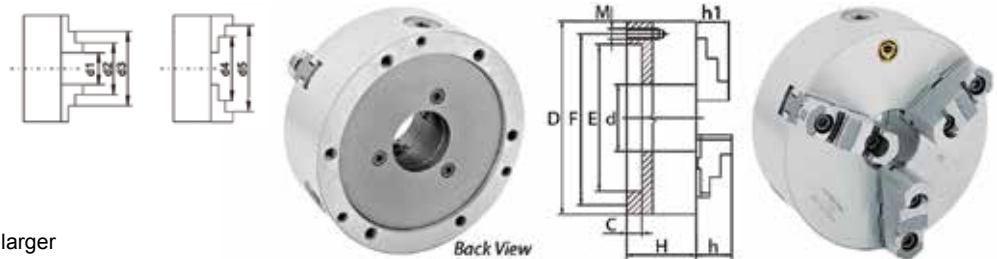

#### Series 3205 - Plain Back Mounting Specifications

Chuck Diameter (Inch)	RPM Max	Weight (lbs.)	d1 Min-Max (Inch)	d2 Min-Max (Inch)	d3 Min-Max (Inch)	d4 Min-Max (Inch)	d5 Min-Max (Inch)	M Thread	L (Inch)	No. of Bolts
5.00	3200	11	0.19 - 1.97	2.05 - 3.78	3.74 - 4.92	1.34 - 2.99	2.95 - 4.65	M8 x 1.25	0.98	3
6.25	3000	22	0.19 - 2.52	2.44 - 4.76	4.53 - 6.30	1.65 - 3.81	3.46 - 5.75	M10 x 1.5	0.98	3
8.00	2500	39	0.16 - 3.54	2.83 - 6.14	5.24 - 7.87	1.97 - 5.12	4.13 - 7.48	M10 x 1.5	0.98	6
10.00	2000	55	0.20 - 4.65	3.39 - 7.76	6.30 - 9.84	2.28 - 6.50	4.92 - 9.25	M12 x 1.75	1.18	6
12.50	1500	110	0.39 - 5.16	4.06 - 8.90	7.48 - 12.40	2.56 - 7.17	5.71 - 10.43	M16 x 2	1.18	6
15.75	1000	187	0.39 - 7.09	5.00 - 11.57	9.06 - 15.75	2.84 - 8.98	6.50 - 12.95	M16 x 2	1.57	6
20.00	700	320	0.79 - 9.25	4.33 - 15.75	7.48 - 19.69	4.72 - 16.14	7.87 - 19.09	M16 x 2	1.57	6
25.00	500	551	1.18 - 13.19	4.72 - 22.44	7.87 - 24.80	5.51 - 23.23	8.27 - 26.18	M16 x 2	1.57	6

#### Plain Back – Series 3205

Chuck Diameter (Inch)	d Hole Diameter (Inch)	Max. Hole Enlargement (Inch)	F (Inch)	E (Inch)	C (Inch)	H (Inch)	h (Inch)	h1 (Inch)	Code
5.00	1.26	1.26	4.25	3.74	0.16	2.20	1.57	0.79	355000
6.25	1.65	1.81	5.51	4.92	0.16	2.54	1.69	1.26	355001
8.00	2.17	2.56	6.93	6.30	0.16	2.95	1.77	1.14	355002
10.00	2.99	3.46	8.82	7.87	0.20	3.35	2.09	1.34	355003
12.50	4.06	4.33	11.26	10.24	0.20	3.70	2.24	1.69	355004
15.75	5.35	5.59	14.25	12.99	0.20	4.13	2.64	2.16	355005
20.00	7.48	8.23	18.03	16.54	0.20	4.72	3.15	2.36	355006
25.00	9.92	11.93	23.07	21.46	0.28	5.31	3.42	2.76	355007

#### Plain Back – Series 3205 – 32 Inch

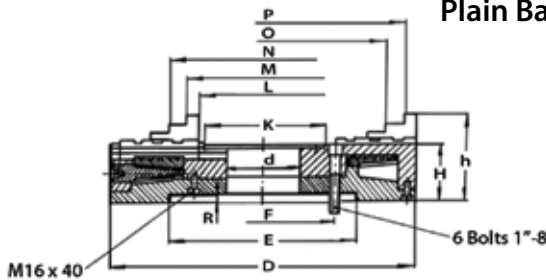

#### Series 3205 - Plain Back Mounting Specifications

Chuck Dia.	RPM Max	Weight (lbs)	Maximum Weight of Workpiece without Support (lbs)	Maximum Weight of Workpiece with Support (lbs)	L Min-Max (Inch)	M Min-Max (Inch)	N Min-Max (Inch)	O Min-Max (Inch)	P Min-Max (Inch)	Screw Thread	Bolt Thread	No. of Bolts
32.00	600	849	882	17637	5.91 - 18.98	9.92 - 28.98	12.91 - 31.50	9.45 - 28.50	12.44 - 31.50	M16 x 40	1-8	6

Chuck Diameter (Inch)	d Hole Diameter (Inch)	Max. Hole Enlargement (Inch)	F (Inch)	E (Inch)	K (Inch)	H (Inch)	h (Inch)	R (Inch)	Code
32.00	10.51	12.60	13.00	14.96	-	5.51	8.94	0.47	355008

## Universal Lathe Chucks

### Semi-Steel Body – 3-Jaw Direct Mount Chucks 2 Pc. Hard Reversible Jaws



Type A1/A2



Back view  
Type A1 Bolt hole pattern

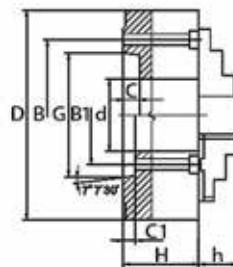

- Semi-steel body
- Type A1 spindle has a two-bolt hole pattern, inside and outside the taper - either A1 or A2 chuck will fit
- Type A2 spindle has a one-bolt hole pattern outside the taper - only an A2 chuck will fit

#### Standard Accessories:

- 1 set of hard master jaws
- 1 set of hard top reversible jaws
- 1 wrench
- 1 set of mounting bolts
- 2 hex keys
- Eye bolts for chuck sizes 15.75" and larger

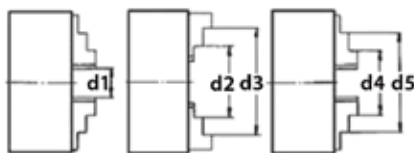

#### Series 3215 - Type A Direct Mounting Specifications

Chuck Diameter (Inch)	RPM Max	Weight (lbs.)	d1 Min-Max (Inch)	d2 Min-Max (Inch)	d3 Min-Max (Inch)	d4 Min-Max (Inch)	d5 Min-Max (Inch)	M Thread	L (Inch)	No. of Bolts
6.25	3000	22	0.19 - 2.52	2.44 - 4.76	4.53 - 6.30	1.65 - 3.81	3.46 - 5.75	7/16-14	2.75	3
8.00	2500	42	0.16 - 3.54	2.83 - 6.14	5.24 - 7.87	1.97 - 5.12	4.13 - 7.48	7/16-14	3.12	3
8.00	2500	42	0.16 - 3.54	2.83 - 6.14	5.24 - 7.87	1.97 - 5.12	4.13 - 7.48	1/2-13	3.12	3
10.00	2000	71	0.20 - 4.65	3.39 - 7.76	6.30 - 9.84	2.28 - 6.50	4.92 - 9.25	7/16-14	4.12	6
10.00	2000	71	0.20 - 4.65	3.39 - 7.76	6.30 - 9.84	2.28 - 6.50	4.92 - 9.25	5/8-11	3.50	6
12.50	1500	121	0.39 - 5.16	4.06 - 8.90	7.48 - 12.40	2.56 - 7.17	5.71 - 10.43	1/2-13	4.75	6
12.50	1500	121	0.39 - 5.16	4.06 - 8.90	7.48 - 12.40	2.56 - 7.17	5.71 - 10.43	5/8-11	4.19	6
15.75	1000	203	0.39 - 7.09	5.00 - 11.57	9.06 - 15.75	2.84 - 8.98	6.50 - 12.95	1/2-13	5.00	6
15.75	1000	203	0.39 - 7.09	5.00 - 11.57	9.06 - 15.75	2.84 - 8.98	6.50 - 12.95	3/4-10	4.25	6
20.00	700	353	0.79 - 9.25	4.33 - 15.75	7.48 - 19.69	4.72 - 16.14	7.87 - 19.09	3/4-10	5.87	6
25.00	500	628	1.18 - 13.19	4.72 - 22.44	7.87 - 24.80	5.51 - 23.23	8.27 - 26.18	3/4-10	7.09	6
25.00	500	628	1.18 - 13.19	4.72 - 22.44	7.87 - 24.80	5.51 - 23.23	8.27 - 26.18	7/8-9	6.00	6

#### A Mount Chucks – Series 3215

Chuck Diameter (Inch)	Mount	d Hole Diameter (Inch)	Max. Hole Enlargement (Inch)	B1 (A1)	B (A2)	G (Inch)	C/C1 (Inch)	H (Inch)	h (Inch)	Code
6.00	A1-5	1.65	1.81	2.44	-	3.25	0.56	3.21	1.69	355010
8.00	A1-5	1.65	2.56	2.44	-	3.25	0.56	3.58	1.77	355011
8.00	A1-6	2.17	2.56	3.25	-	4.19	0.62	3.58	1.77	355012
10.00	A1-8	2.99	3.46	4.37	-	5.50	0.69	4.07	2.09	355014
12.50	A2-6	4.06	4.06	-	5.25	4.19	0.63	4.63	2.24	355015
12.50	A1-8	3.15	4.33	4.37	-	5.50	0.69	4.63	2.24	355016
15.75	A2-6	4.06	4.06	-	5.25	4.19	0.63	5.06	2.64	355017
15.75	A1-11	5.19	5.59	6.50	-	7.75	0.75	5.06	2.64	355018
20.00	A2-11	7.59	7.59	-	9.25	7.75	0.79	5.75	3.09	355019
25.00	A2-11	7.48	7.59	-	9.25	7.75	0.75	6.50	3.42	355020
25.00	A2-15	7.48	11.00	-	13.00	11.25	0.81	6.50	3.42	355021

## Universal Lathe Chucks

Semi-Steel Body – 3-Jaw Direct Mount Chucks

2 Pc. Jaws



### Camlock D1 Chucks – Series 3245

Chuck Diameter (Inch)	Mount	d Hole Diameter (Inch)	B (Inch)	G (Inch)	C (Inch)	H (Inch)	h (Inch)	Code
5.00	D1-4	1.26	3.25	2.50	0.51	2.76	1.57	355023
6.25	D1-3	1.65	2.78	2.12	0.51	3.21	1.69	355024
6.25	D1-4	1.65	3.25	2.50	0.51	3.21	1.69	355025
8.00	D1-3	2.03	2.78	2.12	0.51	3.58	1.77	355026
8.00	D1-4	2.17	3.25	2.50	0.51	3.58	1.77	355027
8.00	D1-5	2.17	4.13	3.25	0.56	3.58	1.77	355028
8.00	D1-6	2.17	5.25	4.19	0.56	3.58	1.77	355029
10.00	D1-5	2.99	4.13	3.25	0.56	4.07	2.09	355030
10.00	D1-6	2.99	5.25	4.19	0.63	4.07	2.09	355031
10.00	D1-8	2.99	6.75	5.50	0.71	4.07	2.09	355032
12.50	D1-6	4.06	5.25	4.19	0.63	4.63	2.24	355033
12.50	D1-8	4.06	6.75	5.50	0.71	4.63	2.24	355034
12.50	D1-11	4.06	9.25	7.75	0.79	5.51	2.24	355035
15.75	D1-6	4.06	5.25	4.19	0.63	5.06	2.64	355036
15.75	D1-8	5.35	6.75	5.50	0.71	5.06	2.64	355037
15.75	D1-11	5.35	9.25	7.75	0.79	5.06	2.64	355038
20.00	D1-8	5.35	6.75	5.50	0.71	5.75	3.15	355039
20.00	D1-11	7.60	9.25	7.75	0.79	5.75	3.15	355040
25.00	D1-11	7.60	9.25	7.75	0.79	6.50	3.42	355041

### Semi-Steel Body – 3-Jaw Self-Centering Chucks

#### Threaded Chucks – Series 3285

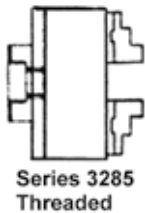

Chuck Diameter (Inch)	Hole Diameter (Inch)	Thread	Approximate Weight (lbs)	Code
5	1.2598	1 - 10	10.0	355055
5	1.2598	1-1/2 - 8	10.0	355056
6	1.6535	1-1/2 - 8	18.1	355057
6	1.6535	2-1/4 - 8	18.1	355058
8	2.1654	1-1/2 - 8	33.7	355059
8	2.1654	2-1/4 - 8	33.7	355060
8	2.1654	2-3/8 - 6	33.7	355061
10	2.9925	2-1/4 - 8	55.3	355062
12	4.0551	2-3/8 - 6	90.4	355063
12	4.0551	2-3/8 - 6	90.4	355064



## Universal Lathe Chucks



### Semi-Steel Body – 3-Jaw Self-Centering Chucks

#### Extra Large Through Hole Chucks

- Series 3295 designed for the pipe industry
- Supplied with base jaws only
- Hard top and soft top jaws sold separately



Chuck Diameter (Inch)	Hole Diameter (Inch)	Jaw Stroke Minimum (Inch)	Jaw Stroke Maximum (Inch)	Weight (lbs)	Maximum RPM	Code
16	8.66	6.61	11.34	127	500	355065
20	12.60	9.87	14.96	167	350	355066
26	15.98	14.80	19.57	300	250	355067

#### Hard & Soft Top Jaws for Extra Large Through Hole Chucks

For Chuck Diameter (Inch)	Hard Top Jaws		Soft Top Jaws	
	Description	Code	Description	Code
16	1 pc.	355303	1 pc.	355306
20	1 pc.	355304	1 pc.	355307
26	1 pc.	355305	1 pc.	355308

### Plain Back – Series 3204

- Semi-steel body
- Two sets of hard solid jaws
- Scroll and jaws hardened and ground

#### Standard Accessories:

- 2 sets of hard solid jaws (inside and outside)
- 1 wrench
- 1 set of mounting screws

#### Optional Accessories:

Soft top jaws

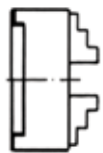

Series 3204  
Plain Back

Chuck Diameter (Inch)	Hole Diameter (Inch)	Approximate Weight (lbs)	Code
3	0.62	3.1	355068
4	0.78	5.3	355069
5	1.25	9.3	355070
6	1.65	17.0	355071
8	2.16	34.0	355072
10	2.99	52.0	355073
12	4.05	87.1	355074
16	5.35	163.4	355075
20	7.48	271.2	355076
25	9.92	469.0	355077

## Precision Lathe Chucks

### Forged Steel Body – 3-Jaw Self-Centering Chucks



- Forged steel body
- Two-piece hard reversible jaws
- Scroll and jaws hardened and precision ground
- Balanced scroll

#### Standard Accessories:

- 1 set of two-piece reversible jaws (hard top and hard master jaws)
- 1 wrench
- 1 set of mounting bolts

#### Optional Accessories:

Soft top jaws



### Plain Back - Series 3505

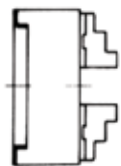

Series 3505  
Plain Back

Chuck Diameter (Inch)	Hole Diameter (Inch)	Approximate Weight (lbs)	Code
5	1.25	10	355089
6	1.65	21	355090
8	2.16	36	355091
10	2.99	75	355092
12	4.05	123	355093
16	5.35	198	355094
20	7.48	276	355095
25	7.48	485	355096

### Camlock - Series 3545

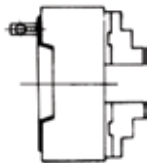

Series 3545  
Camlock

Chuck Diameter (Inch)	Hole Diameter (Inch)	Spindle Type	Approximate Weight (lbs)	Code
6	1.65	D1-3	20	355097
6	1.65	D1-4	20	355098
6	1.65	D1-5	20	355099
8	2.16	D1-5	42	355100
8	2.16	D1-6	42	355101
10	2.99	D1-6	71	355102
10	2.99	D1-8	71	355103
12	4.05	D1-6	112	355104
12	4.05	D1-8	112	355105
12	4.05	D1-11	112	355106
16	5.35	D1-8	223	355107
16	5.35	D1-11	223	355108
20	5.35	D1-8	331	355109
20	7.48	D1-11	331	355110
25	5.35	D1-8	604	355111
25	7.48	D1-11	604	355112

## Precision Lathe Chucks



### Forged Steel – 3-Jaw & 6-Jaw Set-Tru Self-Centering Chucks

Outstanding accuracy, versatility and long life make our “SET-TRU” self-centering chucks invaluable in the workshop and indispensable in the tool room

- Forged steel
- With fine adjustment
- Scroll and jaws hardened and ground
- Three hardened and ground pinions
- Four micro adjustment screws provide 0.0005” TIR repeatability
- Solid inside and outside jaws also available



*NOTE: Set-Tru chucks only accept Set-Tru back plates*

### 3-Jaw – Series 3565 & 6-Jaw – Series 3865

Chuck Diameter (Inch)	Hole Diameter (Inch)	3-Jaw			6-Jaw		
		Approximate Weight (lbs)	Maximum RPM	Code	Approximate Weight (lbs)	Maximum RPM	Code
6	1.65	20.5	3500	355120	25.2	3400	355113
8	2.16	34.5	3000	355121	41.5	3100	355114
10	2.99	59.0	2500	355122	78.9	2700	355115
12	4.05	105.0	2000	355123	128.5	2200	355116
16	5.34	201.0	1800	355124	250.0	1300	355117
20	7.48	374.0	1200	355125	365.0	800	355118
25	9.92	630.0	1000	355126	647.0	700	355119

### Back Plates for 3-Jaw & 6-Jaw Set-Tru Precision Chucks

Set-Tru chucks can be used for many machining operations for which ordinary geared scroll chucks are unsuitable and to all the operations for which ordinary chucks are normally used. A unique micro-adjustment feature, micro adjustment screws No. 2, enables concentricity to be adjusted to 0.0005mm/0.0002” of full indicator movement.

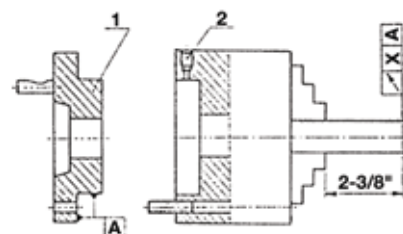

### Camlock

Spindle Type	For Chuck Diameter (Inch)	Code	Spindle Type	For Chuck Diameter (Inch)	Code	Spindle Type	For Chuck Diameter (Inch)	Code
D1-3	6	355127	D1-5	10	355134	D1-11	16	355141
D1-4	6	355128	D1-6	10	355135	D1-8	20	355142
D1-5	6	355129	D1-8	10	355136	D1-11	20	355143
D1-3	8	355130	D1-6	12	355137	D1-15	20	355144
D1-4	8	355131	D1-8	12	355138	D1-8	25	355145
D1-5	8	355132	D1-11	12	355139	D1-11	25	355146
D1-6	8	355133	D1-8	16	355140			

### A Type

Spindle Type	For Chuck Diameter (Inch)	Code	Spindle Type	For Chuck Diameter (Inch)	Code	Spindle Type	For Chuck Diameter (Inch)	Code
A-5	6	355147	A-6	12	355153	A-11	20	355159
A-5	8	355148	A-8	12	355154	A-15	20	355160
A-6	8	355149	A-11	12	355155	A-8	25	355161
A-5	10	355150	A-8	16	355156	A-11	25	355162
A-6	10	355151	A-11	16	355157	A-15	25	355163
A-8	10	355152	A-8	20	355158			

## Universal Lathe Chucks



### Steel/Semi-Steel – 4-Jaw Self-Centering Chucks

- Two-piece hard reversible jaws
- Scroll and jaws hardened and ground

#### Standard Accessories:

- 1 set of two-piece reversible jaws (hard top and hard master jaws)
- 1 wrench
- 1 set of mounting bolts

#### Optional Accessories:

Soft top jaws



#### Semi-Steel – Series 3605

Chuck Diameter (Inch)	Hole Diameter (Inch)	Weight (lbs)	Code
5	1.25	11	355164
6	1.65	22	355165
8	2.17	39	355166
10	2.99	55	355167
12	4.06	110	355168
16	5.35	187	355169
20	7.48	320	355170
25	9.92	551	355171

#### Steel – Series 3605

Chuck Diameter (Inch)	Hole Diameter (Inch)	Weight (lbs)	Code
6	1.65	21	355172
8	2.17	36	355173
10	2.99	75	355174
12	4.06	123	355175
16	5.35	246	355176
20	7.48	331	355177
25	9.92	560	355178

#### Semi-Steel – Series 3604

- Two sets of hard solid jaws
- Scroll and jaws hardened and ground

#### Standard Accessories:

- 2 sets of hard solid jaws (inside and outside),
- 1 wrench
- 1 set of mounting bolts

#### Optional Accessories:

Soft solid jaws



Chuck Diameter (Inch)	Hole Diameter (Inch)	Weight (lbs)	Code
5	1.2548	9.3	355179
6	1.6535	17.9	355180
8	2.1654	31.1	355181
10	2.9921	52.7	355182
12	4.0551	88.8	355183
16	5.3543	165.3	355184
20	7.4803	246.3	355185

## Combination Universal/Independent Lathe Chucks

### Steel/Semi-Steel – 4-Jaw Chucks



#### Semi-Steel – Plain Back – Series 4605

#### Steel – Plain Back – Series 4805

Chuck Diameter (Inch)	Hole Diameter (Inch)	Weight (lbs)	Code
8	2.17	41.4	355190
10	2.99	65.0	355191
12	4.05	120.0	355192
16	5.35	194.0	355193
20	7.48	330.0	355194
25	9.92	551.0	355195

Chuck Diameter (Inch)	Hole Diameter (Inch)	Weight (lbs)	Code
8	2.17	43.0	355196
10	2.99	68.3	355197
12	4.05	124.0	355198
16	5.35	198.0	355199
20	7.48	342.0	355200
25	9.92	573.0	355201

## Independent Lathe Chucks

### Steel/Semi-Steel – 4-Jaw Chucks



- Semi-steel/steel body
- Solid reversible jaws individually adjustable (Steel plain back chuck has two-piece jaws)
- Scroll and jaws hardened and ground

#### Standard Accessories:

- 1 set of solid reversible jaws
- 1 wrench
- 1 set of mounting screws

#### Optional Accessories:

- Set of two-piece reversible jaws
- Soft top jaws



#### Semi-Steel – Plain Back – Series 4304

#### Steel – Plain Back – Series 4303

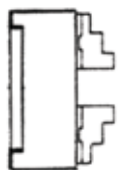

Series 4304 Plain Back

Chuck Diameter (Inch)	Bore Diameter (Inch)	Weight (lbs)	Code
3-1/2	1.00	3.4	355206
5	1.02	8	355207
6	1.65	9	355208
8	1.97	32	355209
10	2.56	55	355210
12	3.15	88	355211
16	3.93	139	355212
20	4.93	231	355213
25	6.30	364	355214
32	7.87	700	355215
32T	10.50	672	355216
36	7.48	800	355217

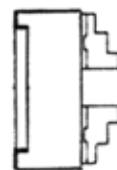

Series 4303 Plain Back

Chuck Diameter (Inch)	Bore Diameter (Inch)	Weight (lbs)	Code
8	1.97	35	355218
10	2.56	59	355219
12	3.15	95	355220
16	3.93	150	355221
20	4.93	250	355222
25	6.30	390	355223
32	7.87	750	355224
36	7.48	856	355225
40	7.48	1367	355226
49	7.48	2138	355227

Steel plain back chucks have two-piece jaws



## Independent Lathe Chucks

Steel/Semi-Steel – 4-Jaw Chucks (continued)

### Semi-Steel – Camlock – Series 4344

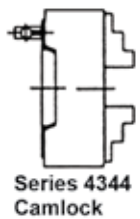

Chuck Diameter (Inch)	Spindle Type	Bore Diameter (Inch)	Weight (lbs)	Code
8	D1-3	1.97	37	355228
8	D1-4	1.97	37	355229
8	D1-5	1.97	37	355230
10	D1-4	2.36	61	355231
10	D1-5	2.56	61	355232
10	D1-6	2.56	61	355233
12	D1-6	3.15	87	355234
12	D1-8	3.15	87	355235
16	D1-6	3.94	132	355236
16	D1-8	3.94	132	355237
16	D1-11	3.94	132	355238
20	D1-8	4.92	211	355239
20	D1-11	4.92	211	355240
25	D1-11	6.30	364	355241

### Semi-Steel – Camlock – Series 4343

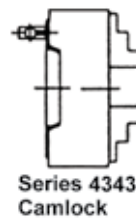

Chuck Diameter (Inch)	Spindle Type	Bore Diameter (Inch)	Weight (lbs)	Code
8	D1-4	3.15	40	355242
8	D1-5	3.15	40	355243
8	D1-6	3.15	40	*355244
10	D1-5	3.35	65	355245
10	D1-6	3.35	65	355246
10	D1-8	3.35	65	355247
12	D1-6	3.74	93	*355248
12	D1-8	3.74	93	355249
16	D1-6	4.13	141	355250
16	D1-8	4.13	141	355251
16	D1-11	4.13	141	355252
20	D1-8	4.72	226	355253
20	D1-11	4.72	226	355254
20	D1-15	4.72	226	355255
25	D1-8	5.51	389	355256
25	D1-11	5.51	389	355257
25	D1-15	5.51	389	355258
32	D1-11	6.20	703	355259
32	D1-15	6.20	703	355260

\* Steel

## Face Plates

- Face plates are designed for use with BISON adapters
- May also be mounted on any lathe spindle nose
- Includes 3 mounting bolts (M)

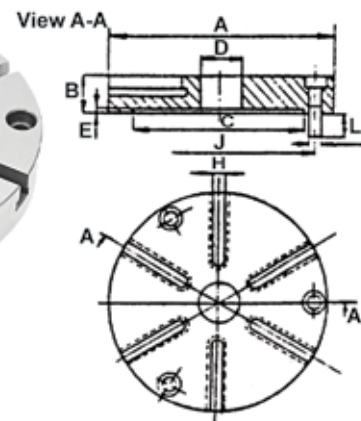

A (Inch)	B (Inch)	C (Inch)	D (Inch)	E +0.008 (Inch)	M Mounting Bolts	L (Inch)	H (Inch)	J +0.008 (Inch)	Weight (lbs)	Code
6-1/4	1.18	4.921	1.18	0.157	M10 x 1.5	0.59	3/8	5.512	7.5	355272
8	1.38	6.299	1.57	0.197	M10 x 1.5	0.59	1/2	6.929	12.0	355273
12-1/2	1.97	10.236	1.97	0.197	M16 x 2	1.02	5/8	11.260	39.0	355274

## Universal Lathe Chucks



### Semi-Steel Body – 3-Jaw & 4-Jaw Front Mount Self-Centering Chucks



3 and 4-Jaw Universal Scroll Chucks are designed for use with rotary tables and other devices where back mounting chucks cannot be used. They can be mounted directly on 3-slot rotary table or on base plate when rotary table has 4 or 8 T-slots.

### Plain Back – 3-Jaw – Solid Jaws

Chuck Diameter (Inch)	Weight (lbs)	Code
4	5.3	355275
8	32.0	355276
10	52.0	355277
12	96.0	355278

### Plain Back – 4-Jaw – 2-Piece Jaws

Chuck Diameter (Inch)	Weight (lbs)	Code
5	10.0	355284
6	18.0	355285
8	32.0	355286
10	52.0	355287
12	96.0	355288

### Plain Back – 3-Jaw – 2-Piece Jaws

Chuck Diameter (Inch)	Weight (lbs)	Code
5	10.0	355279
6	18.0	355280
8	32.0	355281
10	52.0	355282
12	96.0	355283

## Back Plates

- Fully machined for fixturing and mounting 2, 3 or 4-jaw lathe chucks onto rotary tables, etc.
- High carbon steel
- Precision ground for accuracy

For Chuck Diameter (Inch)	Code
6	355550
8	355551
10	355552
12	355553



## Quick Clamping Lathe Chucks

### Steel Body – 3-Jaw & 6-Jaw Self-Centering Chucks



- RPM 100
- TIR 0.00059"
- For drilling and end mill sharpening as well as for fixtures with 5C and MT sockets
- BISON 3 and 6-jaw lever operated, super accurate, low profile chucks are designed to solve tool grinding problems
- Keyless and pinion-less gripping system allows the reduction of clamping and unclamping time to a minimum
- 6-jaw chucks provide a uniform distortion free clamping of workpieces
- Chucks can be mounted on the spindle noses of tool grinders, on rotary tables, indexing fixtures and measuring devices



#### Standard Accessories for 3-Jaw Chucks:

- 1 set of inside jaws
- 1 set of outside jaws
- 1 wrench

#### Standard Accessories for 6-Jaw Chucks:

- 1 set of jaws
- 1 wrench

#### 3-Jaw – Series 3266

Chuck Diameter (Inch)	Hole Diameter (Inch)	RPM Maximum	Weight (lbs)	Code
3	0.95	100	2.4	355289
4	1.26	100	7.1	355290
5	1.50	100	8.8	355291
6-1/4	2.05	100	16.1	355292

#### 6-Jaw – Series 3866

Chuck Diameter (Inch)	Hole Diameter (Inch)	RPM Maximum	Weight (lbs)	Code
3	0.95	100	2.8	355293
4	1.26	100	6.2	355294
5	1.50	100	8.8	355295
6-1/4	2.05	100	15.4	355296

## Quick Clamping Lathe Chuck Adapters

### Fully Machined



Morse Taper



5C



5C Blank

#### Morse Taper

Chuck Diameter (Inch)	Morse Taper	Code
4	3	355554
4	4	355555
5	3	355556
5	4	355557
6	5	355558

#### 5C

Chuck Diameter (Inch)	Code
4	355559
5	355560
6	355561

#### 5C Blank

Chuck Diameter (Inch)	Code
4	355562
5	355563
6	355564



## Universal Lathe Chucks

### Semi-Steel Body – 2-Jaw Self-Centering Chucks



- Semi-steel body
- Two-piece soft top reversible jaws are shaped by user to fit the workpiece
- Scroll and master jaws hardened and ground

#### Standard Accessories:

- 1 set of two-piece reversible soft top jaws and hard master jaws
- 1 wrench
- 1 set of mounting bolts



#### Series 3100

Chuck Diameter (Inch)	Hole Diameter (Inch)	Weight (lbs)	Code
6	1.6535	20.3	355297
8	2.1654	34.5	355298
10	2.9921	56.7	355299
12	4.0551	93.9	355300
16	5.3543	172.8	355301

## Lathe Chuck Accessories

### For Bison Lathe Chucks



#### Back Plates – Fully Machined Cast Iron

Series 8240 - Fully machined adapters for BISON plain back, self-centering chucks – designed for direct mounting on camlock spindle noses

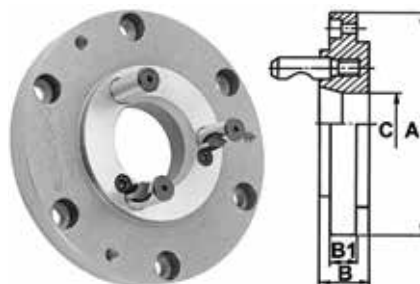

#### Camlock – Series 8240

For Chuck Diameter (Inch)	Taper Size	Stud Diameter (Inch)	No. of Studs	C Diameter (Inch)	A Diameter (Inch)	B (Inch)	B1 (Inch)	Weight (lbs)	Code
5	D1-3	9/16	3	2.02	4.94	1.02	0.57	5.3	355565
5	D1-4	5/8	3	2.40	4.94	1.02	0.87	5.3	355566
6-1/4	D1-3	9/16	3	2.02	6.32	1.06	0.71	9.5	355567
6-1/4	D1-4	5/8	3	2.40	6.32	1.06	0.71	9.5	355568
6-1/4	D1-5	3/4	6	3.13	6.32	1.18	1.00	9.5	355569
6-1/4	D1-6	7/8	6	4.06	6.32	1.44	1.32	9.5	355570
8	D1-3	9/16	3	2.02	7.89	1.06	0.71	15.4	355571
8	D1-4	5/8	3	2.40	7.89	1.06	0.71	15.4	355572
8	D1-5	3/4	6	3.13	7.89	1.18	0.71	15.4	355573
8	D1-6	7/8	6	4.06	7.89	1.44	1.26	15.4	355574
10	D1-5	3/4	6	3.13	9.86	1.18	0.87	24.3	355575
10	D1-6	7/8	6	4.06	9.86	1.44	0.87	24.3	355576
10	D1-8	1	6	5.35	9.86	1.54	1.36	39.7	355577
12-1/2	D1-6	7/8	6	4.06	12.42	1.56	0.94	39.7	355578
12-1/2	D1-8	1	6	5.35	12.42	1.65	0.94	39.7	355579
12-1/2	D1-11	1-3/16	6	7.59	12.42	1.85	1.36	39.7	355580
15-3/4	D1-6	7/8	6	4.06	15.77	1.44	1.10	79.0	355581
15-3/4	D1-8	1	6	5.35	15.77	1.54	1.10	79.0	355582
15-3/4	D1-11	1-3/16	6	7.59	15.77	1.85	1.10	79.0	355583
20	D1-8	1	6	5.35	19.70	1.54	1.14	132.0	355584
20	D1-11	1-3/16	6	7.59	19.70	1.85	1.14	132.0	355585
25	D1-8	1	6	5.35	24.82	1.54	1.14	232.0	355586
25	D1-11	1-3/16	6	7.59	24.82	1.85	1.14	232.0	355587

Number of camlock studs depends on spindle size

## Lathe Chuck Accessories

For Bison Lathe Chucks



### Spindle Back Plates – Cast Iron

Adapters for threaded spindles 3-jaw and 4-jaw universal

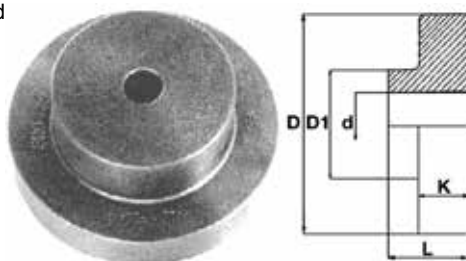

For 4-jaw independent only

#### Series 8205

For Chuck Diameter (Inch)	D (Inch)	d (Inch)	D1 (Inch)	K (Inch)	L (Inch)	Weight (lbs)	Code
3, 4, 5	5.20	0.71	3.46	0.98	2.20	4.4	355663
6-1/4	6.70	0.98	3.46	0.98	2.20	12.0	355664
8	8.30	0.98	4.02	1.18	2.83	22.0	355665
10	10.24	1.57	4.53	1.26	3.54	34.0	355666
12-1/2	12.30	1.97	6.77	1.26	4.02	66.0	355667
15-3/4	16.34	2.76	9.06	2.17	4.92	154.0	355668
20	20.28	3.15	9.84	2.56	5.98	267.0	355669
25	25.20	4.72	11.81	3.35	7.09	496.0	355670

#### Series 8262

For Chuck Diameter (Inch)	D (Inch)	d (Inch)	D1 (Inch)	K (Inch)	L (Inch)	Weight (lbs)	Code
6-1/4	3.94	0.79	2.95	1.18	2.17	8	355671
5	5.12	1.18	3.74	1.38	2.56	11	355672
10	7.09	1.57	4.72	1.97	3.35	25	355673
12-1/2	8.66	2.17	5.51	2.36	3.74	49	355674
15-3/4	10.63	2.95	7.48	2.36	5.51	95	355675
20, 25	11.02	3.54	7.87	2.36	5.51	99	355676
32	15.75	3.54	8.66	2.36	5.51	177	355677

### A Type

Semi machined adapters for plain back chucks, with spotted holes for A1 and A2 spindle noses



For Chuck Diameter (Inch)	Taper Size	Code	For Chuck Diameter (Inch)	Taper Size	Code
5	A-6	355650	12	A-8	355658
5	A-8	355651	16	A-8	355659
6	A-5	355652	16	A-11	355660
8	A-5	355653	20	A-11	355661
8	A-6	355654	25	A-11	355662
10	A-6	355655			
10	A-8	355656			
1	A-6	355657			

### Studs

#### Camlock Studs – D1 Style – Metric



Sold individually

#### DIN Standard Studs – DIN 55027



Sold individually

Taper Size	Diameter (Inch)	No. of Studs Required	Thread	Code
D1-3	9/16	3	M10 x 1	355678
D1-4	5/8	3	M10 x 1	355679
D1-5	3/4	6	M12 x 1	355680
D1-6	7/8	6	M16 x 1.5	355681
D1-8	1	6	M20 x 1.5	355682
D1-11	1-3/16	6	M22 x 1.5	355683
D1-15	1-3/8	6	M24 x 1.5	355684

Taper Size	Diameter (Inch)	No. of Studs Required	Thread	Code
C4	0.768	3	M10	355691
C5	0.770	4	M10	355692
C6	0.845	4	M12	355693
C8	1.065	4	M16	355694
C11	1.337	6	M20	355695

## Lathe Chuck Accessories

### For Bison Self-Centering Lathe Chucks



### Hard Solid Outside & Inside Jaws

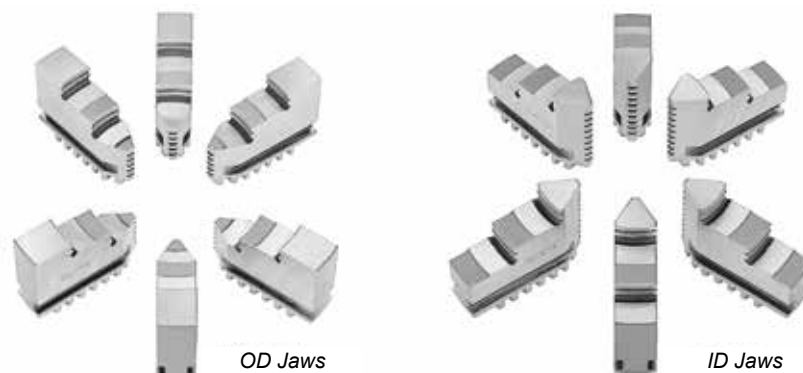

For Chuck Diameter (Inch)	Hard Solid Outside Jaws			Hard Solid Inside Jaws		
	For Series 3200 3-Piece Sets	For Series 3600 4-Piece Sets	For Series 3800 6-Piece Sets	For Series 3200 3-Piece Sets	For Series 3600 4-Piece Sets	For Series 3800 6-Piece Sets
	Code	Code	Code	Code	Code	Code
3	–	–	–	355716	–	–
4	355697	–	–	355717	–	–
5	355698	355704	–	355991	355724	–
6	355989	355705	355712	355992	355725	355732
8	355990	355706	355713	355718	355726	355733
10	355699	355707	355714	355719	355727	–
12	355700	355708	355715	355720	355728	355735
16	355701	–	–	355721	355729	–
20	355702	355710	–	355722	355730	–
25	–	355711	–	–	355731	–

### Soft Solid Jaws

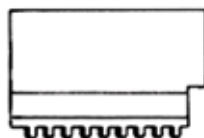

### Hard Top Jaws



For Chuck Diameter (Inch)	For Series 3200 & 3500 3-Piece Sets	For Series 3600 4-Piece Sets	For Chuck Diameter (Inch)	For Series 3200 & 3500 3-Piece Sets	For Series 3600 4-Piece Sets	For Series 3800 6-Piece Sets
	Code	Code		Code	Code	Code
3	355736	–	5	355753	355759	–
4	355737	–	6	355754	355760	355767
5	355738	355745	8	355755	355761	355768
6	355993	355746	10	355756	355762	355769
8	355739	–	12	355757	355763	355770
10	355740	355748	16	355303	–	355771
12	355741	355749	20	355304	355765	355772
16	355742	355750	25	355305	355766	355773
20	–	355751				
25	355744	355752				

## Lathe Chuck Accessories

### For Bison Self-Centering Lathe Chucks



#### Soft Top Jaws



#### Hard Master Jaws



For Chuck Diameter (Inch)	For Series 3100 1-Piece	For Series 3200, 3500, 3600 & 3800 1-Piece
	Code	Code
5	–	355779
6	355774	355780
8	355775	355781
10	355776	355782
12	355777	355783
16	355778	355306
20	–	355307
25	–	355308
32	–	355784

For Chuck Diameter (Inch)	For Series 3100 2-Piece Sets	For Series 3200 & 3500 3-Piece Sets	For Series 3600 4-Piece Sets	For Series 3800 6-Piece Sets
	Code	Code	Code	Code
5	–	355790	355798	–
6	355785	355791	355799	355806
8	355786	355792	355800	355807
10	355787	355793	355801	355808
12	355788	355794	355802	355809
16	355789	355795	355803	355810
20	–	355796	355804	355811
25	–	355797	355805	355812

#### Pinions



#### Scroll Plates



For Chuck Diameter (Inch)	For Series 3100, 3200 & 3600 1-Piece	For Series 3500 1-Piece
	Code	Code
3	355813	–
4	355814	–
5	355815	355824
6	355816	355825
8	355817	355826
10	355818	355827
12	355819	355828
16	355820	355829
20	355821	–
25	355822	–
32	355823	–

For Chuck Diameter (Inch)	For Series 3100, 3200 & 3600 1-Piece	For Series 3500 1-Piece
	Code	Code
3	355830	–
4	355831	355841
5	355832	355842
6	355833	355843
8	355834	355844
10	355835	355845
12	355836	355846
16	355837	355847
20	355838	–
25	355839	–
32	355840	–

## Lathe Chuck Accessories

For Bison Self-Centering & Independent Lathe Chucks



### Jaw Mounting Bolts 1 & 2

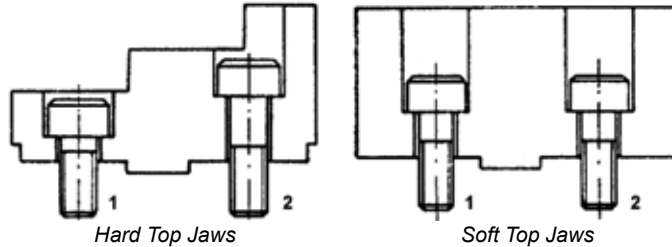

#### Bolt 1

#### Bolt 2

For Chuck Diameter (Inch)	Bolt Size (Inch)	Code
5	5/16 - 18 x 3/4	355848
6	3/8 - 16 x 7/8	355849
8	3/8 - 16 x 1	355850
10	1/2 - 13 x 1-1/8	355851
12	1/2 - 13 x 1-1/8	355851
16	5/8 - 11 x 1-3/8	355852
20	3/4 - 10 x 1-5/8	355853
25	3/4 - 10 x 1-5/8	355853
32	3/4 - 10 x 1-5/8	355853

For Chuck Diameter (Inch)	Bolt Size (Inch)	Code
5	5/16 - 18 x 1	355854
6	3/8 - 16 x 1-1/4	355855
8	3/8 - 16 x 1-3/8	355856
10	1/2 - 13 x 1-5/8	355857
12	1/2 - 13 x 1-5/8	355857
16	5/8 - 11 x 2	355858
20	3/4 - 10 x 3	355859
25	3/4 - 10 x 3-1/8	355860
32	3/4 - 10 x 3-1/8	355860

### Keys for 3-Jaw & 4-Jaw Chucks & 4-Jaw Independent Chucks



#### For 3-Jaw & 4-Jaw Chucks – 1 Piece

#### For 4-Jaw Independent Chucks – 1 Piece

For Chuck Diameter (Inch)	Square (Inch)	Code
3	15/64	355861
4, 5	3/8	355862
10, 12	9/16	355864
16	11/16	355865
20, 25	3/4	355866
32	3/4	355867

For Chuck Diameter (Inch)	Square (Inch)	Code
5, 6	9/32	355868
8, 10	7/16	355869
12, 16	9/16	355870
20, 25	11/16	355871
32	3/4	355872

## Lathe Chuck Accessories

For Bison Independent Lathe Chucks



### Hard Top Jaws – 1 Piece



For Chuck Diameter (Inch)	Code
8	355873
10	355874
12	355875
16	355876
20, 25	355877

### Hard Master Jaws – 1 Piece



For Chuck Diameter (Inch)	Code	For Chuck Diameter (Inch)	Code
8	355880	20	355884
10	355881	25	355885
12	355882	32	355886
16	355883		

### Hard Solid Reversible Jaws – 1 Piece



For Chuck Diameter (Inch)	Code	For Chuck Diameter (Inch)	Code
3	355896	12	355900
6	355897	16	355901
8	355898	20	355902
10	355899	25	355903
		32	355904

### Operating Screws – 1 Piece



For Chuck Diameter (Inch)	Code	For Chuck Diameter (Inch)	Code
3	355887	20	355893
5, 6	355888	25	355894
8	355889	32	355895
10	355890	32	355898
12	355891		
16	355892		

*For chucks with 10-1/2" bore*

### Adapter Mounting Bolts

For Series 4304 – 4-Piece Sets



For Chuck Diameter (Inch)	Bolt Size	Code
6	3/8 - 16 x 1-3/4	355915
8	7/16 - 14 x 2-3/4	355916
10	1/2 - 13 x 3-1/8	355917
12, 16	5/8 - 11 x 3-1/2	355918
20	3/4 - 10 x 4	355919
25	3/4 - 10 x 4-3/4	355920
32	7/8 - 9 x 5-7/8	355921

### Thrust Bearings – 1 Piece



For Chuck Diameter (Inch)	Code	For Chuck Diameter (Inch)	Code
3	355905	12	355909
5, 6	355906	16	355910
8	355907	20	355911
10	355908	25	355912
		32	355913

## Lathe Chuck Accessories

### Steel Serrated Soft Jaws – 3-Piece Sets

#### For Kitagawa Style & Other Power Chucks



\* Standard height



Extra height

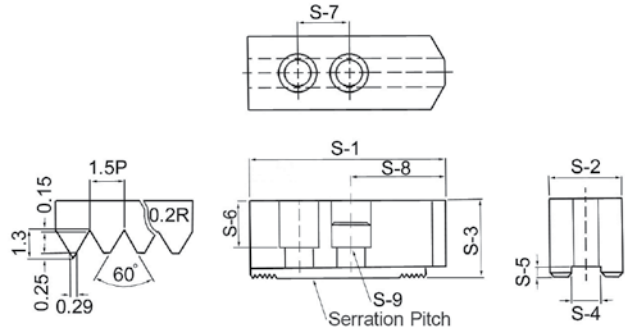

For Chuck Diameter (Inch)	S1 (mm)	S2 (mm)	S3 (mm)	S4 (mm)	S5 (mm)	S6 (mm)	S7 (mm)	S8 (mm)	S9 (mm)	S10 (mm)	S11 (mm)	S12 (mm)	S13 (mm)	S14 Thread	Nose	Code
6	73	31	* 31	12	5	15	20	38	17	11	23	–	14	M10	B	302200
6	73	31	50	12	5	15	20	38	17	11	23	–	14	M10	B	302323
6	73	31	80	12	5	15	20	38	17	11	23	–	14	M10	B	302324
8	95	35	* 37	14	5	24	25	46	19	13	20	–	16	M12	B	302201
8	95	35	50	14	5	24	25	46	19	13	20	–	16	M12	B	302325
8	95	35	80	14	5	24	25	46	19	13	20	–	16	M12	B	302326
10	110	40	42	16	5	30	30	50	19	13	26	20	18	M12	B	302202
10	110	40	60	16	5	30	30	50	19	13	26	20	18	M12	B	302327
10	110	40	90	16	5	30	30	50	19	13	26	20	18	M12	B	302328
10	110	40	120	16	5	30	30	50	19	13	26	20	18	M12	B	302329
12	129	48	* 48	18	6	39	30	60	23	16	30	30	20	M16	B	302203
12	129	48	80	18	6	39	30	60	23	16	30	30	20	M16	B	302331
12	129	48	100	18	6	39	30	60	23	16	30	30	20	M16	B	302333
12	129	48	120	18	6	39	30	60	23	16	30	30	20	M16	B	302335
12	129	48	* 48	21	6	39	30	60	23	16	30	30	20	M16	B	302320
12	129	48	80	21	6	39	30	60	23	16	30	30	20	M16	B	302330
12	129	48	100	21	6	39	30	60	23	16	30	30	20	M16	B	302332
12	129	48	120	21	6	39	30	60	23	16	30	30	20	M16	B	302334
15	165	62	* 62	22	8	37	43	85	32	21	38	50	–	M20	A	302204
15	165	62	80	22	8	37	43	85	32	21	38	50	–	M20	A	302336
15	165	62	130	22	8	37	43	85	32	21	38	50	–	M20	A	302338
15	165	62	* 62	25.5	8	37	43	85	32	21	38	50	–	M20	A	302321
15	165	62	80	25.5	8	37	43	85	32	21	38	50	–	M20	A	302337
15	165	62	130	25.5	8	37	43	85	32	21	38	50	–	M20	A	302339
18	165	62	* 62	22	8	37	43	85	32	21	38	50	–	M20	A	302204
18	165	62	150	22	8	37	43	85	32	21	38	50	–	M20	A	302340
18	165	62	* 62	25.5	8	37	43	85	32	21	38	50	–	M20	A	302321
18	165	62	150	25.5	8	37	43	85	32	21	38	50	–	M20	A	302322

## Steel Serrated Soft Jaws Reference Chart

### Major Brand Crossover

For Chuck Diameter (Inch)	KAR Code	Kitigawa	Samchully	Howa	SMW	MMK	Strong
6	302200	BB-06, B-06, B-206, BT-06, BT206	HS-06	HO15M6, HO22M6, HO24M6, HO27M6	170BBM-CC	YA5-6-46	N206
	302323						
	302324						
8	302201	B-08, B208, BB-208, BB208	-	H3KT8, HO15M8, HO7M8	BHM-210, BBM-210, KT8MH	ZA6-9, HA6-8	-
	302325						
	302326						
10	302202	B-10, B-210, BL-210, BLT-210, BB210	HS10, HC10, HCH10, HCH210	H3KT10	ANM250, BHM-250, BBM-250	HA6-10, HA8-10, HA8-11, PC-10-78-A6, PC-10-78-A8	V210, NIT210, NB210, N210
	302327						
	302328						
	302329						
12	302203	B-12, BT-12, HO-12, HOB-12, HOH-12	-	HO12M12, HO22M10, HO24M10, HO27M10	-	H-12, HA8-12, ZA8-12, ZJA8-12	-
	302331						
	302333						
	302335						
	302320	B-212, BB-212, BL-212, BLT-212, BL212, BT-212	-	H3KT12	BBM-305, BBM-315, BHM-305, BHM-315	ZA8-12-93B	-
	302330						
	302332						
302334							
15	302204	B15, BT-15, B-18, HOH-15K, B-380, B-450, HOB-15, HOB-18, HOH-15, HOH-18, HOH-380	-	-	-	-	-
	302336						
	302338						
	302321	B-215, N15, N18	-	-	-	-	-
	302337						
	302339						
18	302204	B15, BT-15, B-18, HOH-15K, B-380, B-450, HOB-15, HOB-18, HOH-15, HOH-18, HOH-380	-	-	-	-	-
	302340						
	302321	B-215, N15, N18	-	-	-	-	-
	302322						



## Oil Country Lathe Chucks 4-Jaw Independent Chuck & Accessories

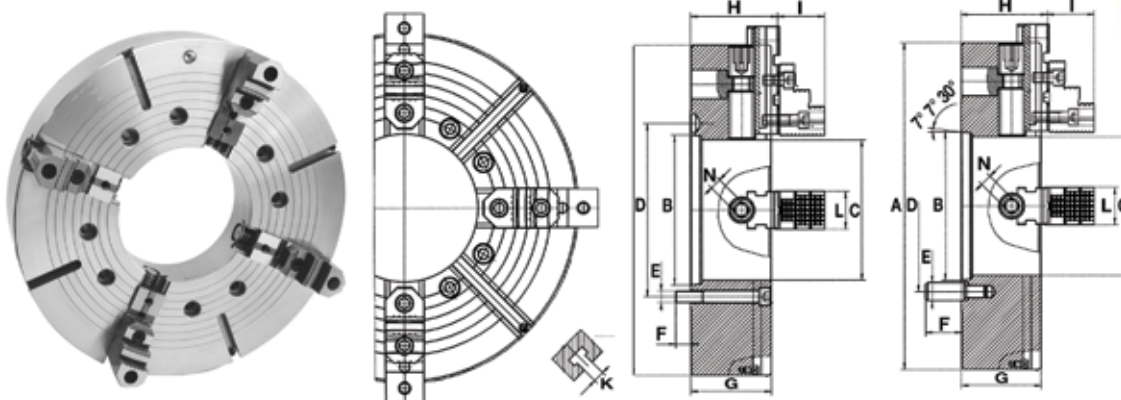

- Extra heavy-duty forged steel body

**Standard Accessories:**

- 1 set of two-piece reversible jaws (hard top and hard master jaws)
- 1 wrench
- 1 set of mounting bolts
- 2 Allen keys
- 2 eye bolts

**Optional Accessories:**

- Soft top jaws

Chuck Diameter (Inches)	Hole Diameter (Inches)	Gripping Force (lbs)	Clamping Capacity (Inches)	
			Minimum	Maximum
15-3/4	5.3	7060	1.77	15.75
15-3/4	6.5	7060	1.77	15.75
20	5.3	7060	1.77	19.68
20	6.5	7060	1.77	19.68
20	8.0	7060	1.77	19.68
25	10.5	8160	1.97	24.80
25	12.5	8160	3.94	24.80
28	10.5	9040	2.95	27.95
28	12.5	9040	3.94	27.95
32	10.5	9040	2.95	31.50
32	12.5	9040	4.53	31.50

### A Type Spindle

D Chuck Diameter (Inch)	Mounting Type	C Hole Diameter (Inch)	B +001" (Inch)	D (Inch)	G (Inch)	H (Inch)	I (Inch)	K (Inch)	L (Inch)	N (Inch)	Maximum RPM	Weight (lbs)	Code
20	A2-15	8.0	11.251	13.000	5.71	6.067	2.981	0.866	2.362	0.748	1000	414	355309
25	A2-15	10.5	11.251	13.000	6.10	6.579	3.571	0.866	2.953	0.866	850	684	355310
25	A2-20	12.5	16.251	18.252	6.10	6.579	3.571	0.866	2.953	0.866	850	662	355311
28	A2-15	10.5	11.251	13.000	6.10	6.579	3.571	0.866	2.953	0.866	750	915	355312
28	A2-20	12.5	16.251	18.252	6.10	6.579	3.571	0.866	2.953	0.866	750	871	355313
32	A2-15	10.5	11.251	13.000	6.50	6.972	3.571	0.866	2.953	0.866	600	1290	355314
32	A2-20	12.5	16.251	18.252	6.50	6.972	3.571	0.866	2.953	0.866	600	1246	355315

### D1 Type Spindle

D Chuck Diameter (Inch)	Mounting Type	C Hole Diameter (Inch)	B +001" (Inch)	D (Inch)	G (Inch)	H (Inch)	I (Inch)	K (Inch)	L (Inch)	N (Inch)	Maximum RPM	Weight (lbs)	Code
15-3/4	D1-8	5.3	5.500	6.750	5.71	6.067	2.981	0.709	2.362	0.748	1200	300	355316
15-3/4	D1-11	6.5	7.750	9.252	5.71	6.067	2.981	0.709	2.362	0.748	1200	282	355317
20	D1-8	5.3	5.500	6.750	5.71	6.067	2.981	0.866	2.362	0.748	1000	468	355318
20	D1-11	6.5	7.750	9.252	5.71	6.067	2.981	0.866	2.362	0.748	1000	452	355319
28	D1-11	7.5	7.750	9.252	6.10	6.579	3.570	0.866	2.953	0.866	750	993	355320

# Oil Country Lathe Chucks

## 4-Jaw Independent Chuck & Accessories (continued)



### Hard Top Reversible Jaws – 1 Piece



For Chuck Diameter (Inch)	Code	For Chuck Diameter (Inch)	Code
15-3/4, 20	355922	25, 28, 32	355923

### Hard Master Jaws – 4-Piece Sets



For Chuck Diameter (Inch)	Code	For Chuck Diameter (Inch)	Code
15-3/4	355924	25, 28, 32	355926
20	355925		

### Thrust Bearings – 1 Piece



For Chuck Diameter (Inch)	Code	For Chuck Diameter (Inch)	Code
15-3/4	355927	25, 28	355929
20	355928	32	355930

### Keys – 1 Piece



For Chuck Diameter (Inch)	Code	For Chuck Diameter (Inch)	Code
15-3/4, 20	355931	25, 28, 32	355932

### Operating Screws – 1 Piece



For Chuck Diameter (Inch)	Hole Diameter (Inch)	Code	For Chuck Diameter (Inch)	Hole Diameter (Inch)	Code	For Chuck Diameter (Inch)	Hole Diameter (Inch)	Code
15-3/4	5.3	355933	20	8.0	355937	28	12.5	355941
15-3/4	6.5	355934	25	10.5	355938	32	10.5	355942
20	5.3	355935	25	12.5	355939	32	12.5	355943
20	6.5	355936	28	10.5	355940			

## Precision Lathe Chucks & Accessories



### PO Series – Forged Steel Body – 3-Jaw Self-Centering Chucks 2 Pc. Hard Reversible Jaws

- Forged steel body, medium duty
- 3 pinion design

**Each chuck is provided with:**

- 1 set of hard master jaws
- 1 set of hard top reversible jaws
- 1 chuck wrench
- 1 set of mounting bolts
- 2 hex keys
- Eye bolts for chuck sizes larger than 10"

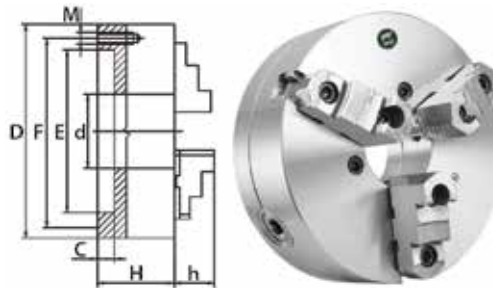

#### Plain Back Mounting

Chuck Diameter (Inch)	d Hole Diameter (Inch)	RPM Maximum	Model	C (Inch)	E (Inch)	F (Inch)	H (Inch)	h (Inch)	M Thread	Bolt Length (Inch)	No. of Bolts	Code
6	1.65	4500	PO3-6"A	0.16	4.92	5.51	2.76	1.69	M10 x 1.5	0.98	6	410048
8	2.17	4000	PO3-8"A	0.16	6.30	6.93	3.15	1.77	M10 x 1.5	0.98	6	410049
10	2.99	3500	PO3-10"A	0.20	7.87	8.82	3.54	2.09	M12 x 1.75	1.18	6	410050
12	4.06	2800	PO3-12"A	0.20	10.24	11.26	3.94	2.24	M16 x 2	1.18	6	410051
16	5.35	2000	PO3-16"A	0.20	12.99	14.25	4.33	2.69	M16 x 2	1.57	6	410052
20	7.48	1200	PO3-20"A	0.20	16.54	18.03	4.68	3.15	M16 x 2	1.57	6	410053
25	9.92	1000	PO3-25"A	0.28	21.46	23.07	5.08	3.42	M16 x 2	1.57	6	410054

#### Type A Mounting



Type A1/A2

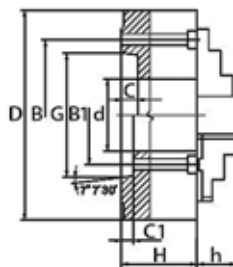

Chuck Diameter (Inch)	d Hole Diameter (Inch)	RPM Maximum	Model	B1 Type A1 (Inch)	B Type A2 (Inch)	*C/C1 (Inch)	G (Inch)	H (Inch)	h (Inch)	M Thread	Bolt Length (Inch)	No. of Bolts	Code
8	2.17	4000	PO3-8"A/A1-6	3.25	-	0.62	4.19	3.07	1.77	1-2/13	2.75	3	410059
10	2.17	3500	PO3-10"A/A1-6	3.25	-	0.62	4.19	3.50	2.09	1-2/13	3.12	6	410060
10	2.99	3500	PO3-10"A/A1-8	4.37	-	0.69	5.50	3.50	2.09	5/8-11	2.75	6	410061
12	4.06	2800	PO3-12"A/A2-6	-	5.25	0.63	4.19	3.79	2.24	1-2/13	4.00	6	410062
12	3.15	2800	PO3-12"A/A1-8	4.37	-	0.69	5.50	3.79	2.24	5/8-11	3.12	6	410063
16	5.12	2000	PO3-16"A/A1-11	6.5	-	0.75	7.75	4.25	2.64	3/4-10	4.50	6	410064
20	7.48	1200	PO3-20"A/A2-11	-	9.25	0.79	7.75	4.68	3.09	3/4-10	4.75	6	410065

\* C-C1 = depth of counterbore

## Precision Lathe Chucks & Accessories



### PO Series – Forged Steel Body – 3-Jaw Self-Centering Chucks 2 Pc. Hard Reversible Jaws (continued)

#### Camlock Mounting

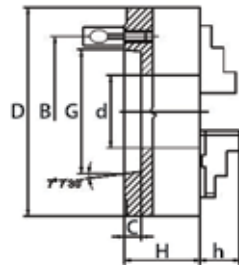

Chuck Diameter (Inch)	d Hole Diameter (Inch)	RPM Maximum	Model	B (Inch)	C (Inch)	G (Inch)	H (Inch)	h (Inch)	Camlock Stud Diameter (Inch)	Camlock Stud Thread	No. of Bolts	Code
6	1.65	4500	PO3-6"A/D1-3	2.75	0.51	2.12	2.68	1.69	0.56	M10 x 1.0	3	356361
6	1.65	4500	PO3-6"A/D1-4	3.25	0.51	2.50	2.68	1.69	0.62	M10 x 1.0	3	356362
6	1.65	4500	PO3-6"A/D1-5	4.13	0.56	3.75	2.68	1.69	0.75	M12 x 1.0	6	356363
8	2.17	4000	PO3-8"A/D1-5	4.13	0.56	3.25	3.07	1.77	0.75	M12 x 1.0	6	356364
8	2.17	4000	PO3-8"A/D1-6	5.25	0.63	4.19	3.07	1.77	0.87	M16 x 1.5	6	356365
10	2.99	3500	PO3-10"A/D1-6	5.25	0.63	4.19	3.50	2.09	0.87	M16 x 1.5	6	410055
10	2.99	3500	PO3-10"A/D1-8	6.75	0.71	5.50	3.50	2.09	1.00	M20 x 1.5	6	410056
12	4.06	2800	PO3-12"A/D1-6	5.25	0.63	4.19	3.79	2.24	0.87	M16 x 1.5	6	410057
12	4.06	2800	PO3-12"A/D1-8	6.75	0.71	5.50	3.79	2.24	1.00	M20 x 1.5	6	410058
12	4.06	2800	PO3-12"A/D1-11	9.25	0.79	7.75	4.40	2.24	1.19	M22 x 1.5	6	356366
16	5.35	2000	PO3-16"A/D1-8	6.75	0.71	5.50	4.26	2.64	1.00	M20 x 1.5	6	356367
16	5.35	2000	PO3-16"A/D1-11	9.25	0.79	7.75	4.26	2.64	1.19	M22 x 1.5	6	356368
20	7.60	1200	PO3-20"A/D1-11	9.25	0.79	7.75	4.68	3.15	1.19	M22 x 1.5	6	356369
25	7.48	1000	PO3-25"A/D1-11	9.25	0.79	7.75	5.08	3.42	1.19	M22 x 1.5	6	356370

#### Spare Jaws for PO Series

Hard jaws, supplied as supplement or as spares, must be ground on the chuck, otherwise centering accuracy does not conform the limits

#### Hard Top Jaws – 3-Piece Sets

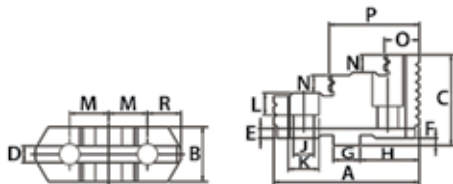

For Chuck Diameter (Inch)	B (Inch)	C (Inch)	D (Inch)	E (Inch)	F (Inch)	G (Inch)	H (Inch)	J (Inch)	K (Inch)	M (Inch)	N (Inch)	A OAL (Inch)	O (Inch)	P (Inch)	Weight (lbs)	Code
6	0.98	1.63	0.31	0.16	0.13	0.50	1.12	0.43	0.71	0.75	0.33	2.64	0.81	1.69	1.20	410140
8	1.18	1.77	0.31	0.16	0.13	0.50	1.37	0.43	0.71	0.87	0.41	3.35	0.98	2.09	2.10	410141
10	1.42	2.09	0.50	0.16	0.13	0.75	1.56	0.55	0.78	1.06	0.53	3.74	1.14	2.52	3.20	410142
12	1.65	2.28	0.50	0.16	0.13	0.75	1.87	0.55	0.78	1.25	0.69	4.25	1.22	3.01	5.10	410143
16	1.77	2.76	0.50	0.16	0.25	0.75	2.25	0.71	1.00	1.50	0.69	5.00	1.85	3.46	7.30	410144
20	1.98	3.42	0.50	0.16	0.25	0.75	2.25	0.87	1.30	1.50	0.79	5.16	2.05	3.23	14.40	410145
25	2.05	3.42	0.50	0.16	0.25	0.75	2.25	0.87	1.30	1.50	0.79	5.16	2.05	3.23	27.10	356302

## Precision Lathe Chucks & Accessories



### Spare Jaws for PO Series (continued)

Hard jaws, supplied as supplement or as spares, must be ground on the chuck, otherwise centering accuracy does not conform the limits

#### Hard Master Jaws – 3-Piece Sets

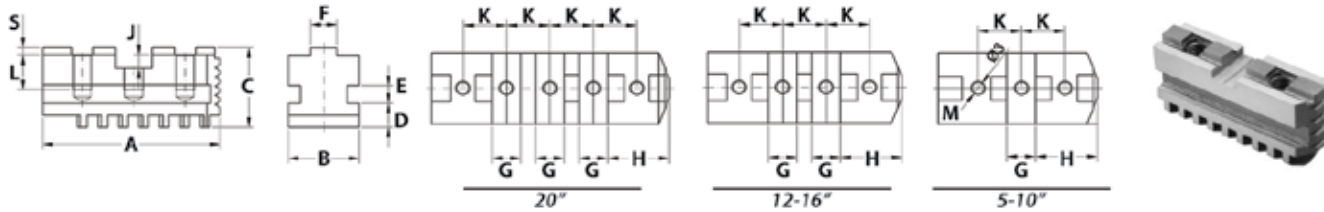

For Chuck Diameter (Inch)	B (Inch)	D (Inch)	E (Inch)	F (Inch)	G (Inch)	H (Inch)	J (Inch)	K (Inch)	L (Inch)	A OAL (Inch)	S (Inch)	M Thread	Weight (lbs)	Code
6	0.79	0.31	0.31	0.31	0.50	1.12	0.16	0.75	0.55	2.56	0.13	3/8-16	1.20	410152
8	0.98	0.35	0.39	0.31	0.50	1.37	0.16	0.87	0.55	3.11	0.13	3/8-16	2.10	410153
10	1.10	0.43	0.47	0.50	0.75	1.56	0.16	1.06	0.63	3.62	0.13	1/2-13	3.20	410154
12	1.26	0.50	0.47	0.50	0.75	1.87	0.16	1.25	0.63	4.33	0.13	1/2-13	5.10	410155
16	1.42	0.59	0.55	0.50	0.75	2.25	0.28	1.50	0.87	5.12	0.25	5/8-11	7.30	410156
20	1.57	0.63	0.55	0.50	0.75	2.25	0.28	1.50	1.26	6.54	0.25	3/4-10	14.40	410157
25	1.97	0.63	0.55	0.50	0.75	2.25	0.28	1.50	1.26	8.27	0.25	3/4-10	27.10	356312

#### Soft Top Jaws – 1 Piece

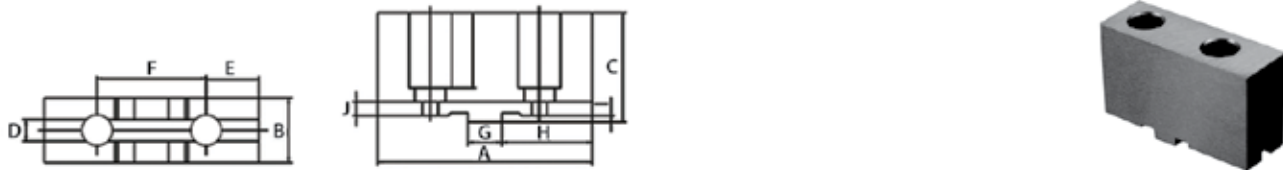

For Chuck Diameter (Inch)	A (Inch)	B (Inch)	C (Inch)	D (Inch)	E (Inch)	F (Inch)	G (Inch)	H (Inch)	I (Inch)	J (Inch)	M Thread	Weight (lbs)	Code
6	3.07	1.00	1.63	0.31	0.84	1.50	0.50	1.34	0.13	0.16	3/8-16	1.01	410146
8	3.54	1.06	1.71	0.31	0.95	1.75	0.50	1.57	0.13	0.16	3/8-16	1.43	410147
10	4.17	1.28	2.03	0.50	1.08	2.12	0.75	1.77	0.13	0.16	1/2-13	2.54	410148
12	4.72	1.57	2.16	0.50	1.21	2.50	0.75	2.09	0.13	0.16	1/2-13	3.53	410149
16	5.51	1.65	2.54	0.50	1.35	3.00	0.75	2.48	0.25	0.16	5/8-11	4.85	410150
20	5.51	1.97	2.93	0.50	1.35	3.00	0.75	2.48	0.25	0.16	3/4-10	5.29	410151
25	6.30	2.05	3.29	0.50	1.35	3.00	0.75	2.48	0.25	0.16	3/4-10	9.26	411044

## Precision Lathe Chucks &amp; Accessories

**gator chucks™**  
BY FUENDA

## Spare Parts for PO Series

## Scroll Plates – 1 Piece



For Chuck Diameter (Inch)	Code
6.25	410116
8.00	410117
10.00	410118
12.50	410119
15.75	410120
20.00	410121

## Keys – 1 Piece



For Chuck Diameter (Inch)	Code
6.25	410129
8.00	410129
10.00	410130
12.50	410131
15.75	410132
20.00	410133

## Pinions – 1 Piece



For Chuck Diameter (Inch)	Code
6.25	411000
8.00	410104
10.00	410105
12.50	410106
15.75	410107
20.00	411002

## Pinion Sleeves – 1 Piece



For Chuck Diameter (Inch)	Code
6.25	411004
8.00	410108
10.00	410109
12.50	410110
15.75	410111
20.00	411006

## Half Rings – 1 Piece



For Chuck Diameter (Inch)	Code
6.25	411008
8.00	410112
10.00	410113
12.50	410114
15.75	410115
20.00	411010

## Universal Lathe Chucks & Accessories



### PS Series – Semi-Steel Body – 3-Jaw & 4-Jaw Self-Centering Chucks

#### 2 Pc. Hard Reversible Jaws

- Semi-steel body, medium duty
- 3 pinion design

**Each chuck is provided with:**

- 1 set of hard master jaws
- 1 set of hard top reversible jaws
- 1 chuck wrench
- 1 set of mounting bolts
- 2 hex keys
- Eye bolts with 10-32" chucks
- Adapters required for plain back mounting

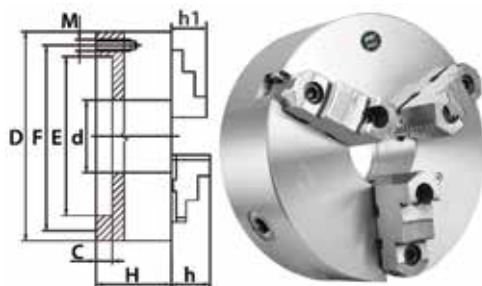

**PS Series - Plain Back Mounting Specifications**

Chuck Diameter (Inch)	RPM Max	M Thread	L (Inch)	No. of Bolts
5	3200	M8 x 1.25	0.98	3
6	3000	M10 x 1.5	0.98	6
8	2500	M10 x 1.5	0.98	6
10	2000	M12 x 1.75	1.18	6
12	1500	M16 x 2	1.18	6
16	1000	M16 x 2	1.57	6
20	700	M16 x 2	1.57	6
25	500	M16 x 2	1.97	6
32	300	1-8	5.96	6

#### Plain Back Mounting – 3-Jaw Chucks

Chuck Diameter (Inch)	d Hole (Inch)	Maximum Hole Enlargements (Inch)	Model	C (Inch)	E (Inch)	F (Inch)	H (Inch)	h (Inch)	h1 (Inch)	Code
5	1.26	1.35	PS3-5"A	0.16	3.74	4.25	2.20	1.57	0.79	356373
6	1.65	1.93	PS3-6"A	0.16	4.92	5.51	2.54	1.69	1.26	410009
8	2.17	2.82	PS3-8"A	0.16	6.30	6.93	2.95	1.77	1.14	410010
10	2.99	3.58	PS3-10"A	0.20	7.87	8.82	3.35	2.09	1.34	410003
12	4.06	4.33	PS3-12"A	0.20	10.24	11.26	3.70	2.24	1.69	410007
16	5.35	5.75	PS3-16"A	0.20	12.99	14.25	4.13	2.69	2.16	410008
20	7.48	8.35	PS3-20"A	0.24	16.54	18.03	4.53	3.50	2.20	356374
25	9.92	12.05	PS3-25"A	0.28	21.46	23.07	5.16	3.46	2.76	356375
32	12.60	-	PS3-32"A	0.79	17.72	14.50	6.26	3.46	2.76	356376

#### Camlock Mounting – 3-Jaw Chucks

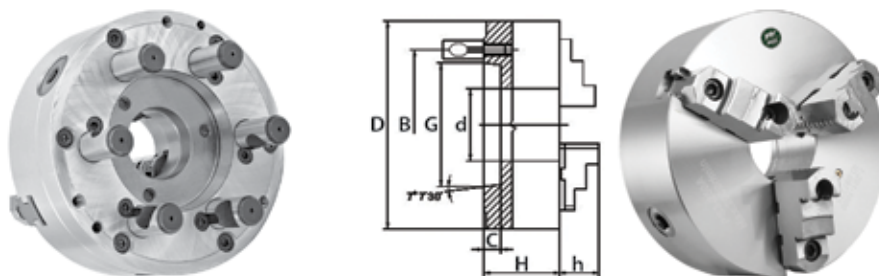

**PS Series - Camlock Mounting Specifications**

Chuck Diameter (Inch)	RPM Max	Weight (lbs)	Taper Size	Camlock Stud Diameter (Inch)	Camlock Stud Thread	No. of Studs
5	3200	11	D1-4	0.62	M10 x 1.0	3
6	3000	20	D1-3	0.56	M10 x 1.0	3
6	3000	20	D1-4	0.62	M10 x 1.0	3
8	2500	42	D1-3	0.56	M10 x 1.0	3
8	2500	42	D1-4	0.62	M10 x 1.0	3
8	2500	42	D1-5	0.75	M12 x 1.0	6
8	2500	42	D1-6	0.87	M16 x 1.5	6
10	2000	71	D1-5	0.75	M12 x 1.0	6
10	2000	71	D1-6	0.87	M16 x 1.5	6
10	2000	71	D1-8	1.00	M20 x 1.5	6
12	1500	112	D1-6	0.87	M16 x 1.5	6
12	1500	112	D1-8	1.00	M20 x 1.5	6
12	1500	112	D1-11	1.19	M22 x 1.5	6
16	1000	223	D1-6	0.87	M16 x 1.5	6
16	1000	223	D1-8	1.00	M20 x 1.5	6
16	1000	223	D1-11	1.19	M22 x 1.5	6
20	700	331	D1-8	1.00	M20 x 1.5	6
20	700	331	D1-11	1.19	M22 x 1.5	6
25	500	604	D1-11	1.19	M22 x 1.5	6

## Universal Lathe Chucks & Accessories



### PS Series – Semi-Steel Body – 3-Jaw & 4-Jaw Self-Centering Chucks

#### 2 Pc. Hard Reversible Jaws (continued)

#### Camlock Mounting – 3-Jaw Chucks (continued)

Chuck Diameter (Inch)	d Hole Diameter (Inch)	Maximum Hole Enlargements (Inch)	Model	B (Inch)	C (Inch)	G (Inch)	H (Inch)	h (Inch)	Code
5	1.26	1.26	PS3-5"A/D1-4	3.25	0.51	2.50	2.76	1.57	356350
6	1.65	1.97	PS3-6"A/D1-3	2.78	0.51	2.12	3.21	1.69	356351
6	1.65	1.97	PS3-6"A/D1-4	3.25	0.51	2.50	3.21	1.69	410011
8	2.03	2.03	PS3-8"A/D1-3	2.78	0.51	2.12	3.58	1.77	356352
8	2.17	2.36	PS3-8"A/D1-4	3.25	0.51	2.50	3.58	1.77	356353
8	2.17	2.64	PS3-8"A/D1-5	4.13	0.56	3.25	3.58	1.77	356354
8	2.17	2.64	PS3-8"A/D1-6	5.25	0.56	4.19	3.58	1.77	410012
10	2.99	2.99	PS3-10"A/D1-5	4.13	0.56	3.25	4.07	2.09	356355
10	2.99	3.74	PS3-10"A/D1-6	5.25	0.63	4.19	4.07	2.09	410013
10	2.99	3.74	PS3-10"A/D1-8	6.75	0.71	5.50	4.07	2.09	410014
12	4.06	4.06	PS3-12"A/D1-6	5.25	0.63	4.19	4.63	2.24	410015
12	4.06	4.53	PS3-12"A/D1-8	6.75	0.71	5.50	4.63	2.24	410006
12	4.06	4.50	PS3-12"A/D1-11	9.25	0.79	7.75	5.51	2.24	410016
16	4.06	4.06	PS3-16"A/D1-6	5.25	0.63	4.19	5.06	2.64	356356
16	5.35	5.35	PS3-16"A/D1-8	6.75	0.71	5.50	5.06	2.64	410017
16	5.35	5.91	PS3-16"A/D1-11	9.25	0.79	7.75	5.06	2.64	410018
20	5.35	5.35	PS3-20"A/D1-8	6.75	0.71	5.50	5.67	3.50	356357
20	7.59	7.60	PS3-20"A/D1-11	9.25	0.79	7.75	5.67	3.50	410019
25	7.59	7.60	PS3-25"A/D1-11	9.25	0.79	7.75	6.50	3.46	356358

#### Front Mounting – 3-Jaw & 4-Jaw Chucks

- Semi-steel body, medium duty
- 3-jaw chuck has 3 pinion design, 4-jaw chuck has 2 pinion design
- Designed for use on grinders, lathes, rotary tables, indexers and a variety of turning and milling applications where back mounting chucks cannot be used

#### Each chuck is provided with:

- 1 set of hard master jaws
- 1 set of hard top reversible jaws
- 1 chuck wrench
- 1 set of mounting bolts
- 2 hex keys
- Eye bolts with 10-32" chucks



Chuck Diameter (Inch)	d Hole Diameter (Inch)	C (Inch)	E (H7) (Inch)	F (Inch)	H (Inch)	h (Inch)	h1 (Inch)	G Screw Thread	M Bolt Thread	3-Jaw Chucks		4-Jaw Chucks	
										Model	Code	Model	Code
6	1.65	0.16	4.92	5.51	2.56	1.69	1.26	3/8-16 x 2.76	M10	PS3-6"A(F)	410000	PS4-6"A(F)	410020
8	2.17	0.16	6.30	6.93	2.95	1.77	1.14	3/8-16 x 3.15	M10	PS3-8"A(F)	410001	PS4-8"A(F)	410021
10	2.99	0.20	7.87	8.82	3.35	2.09	1.34	1/2-13 x 3.54	M12	PS3-10"A(F)	410002	PS4-10"A(F)	410022
12	4.06	0.20	10.24	11.26	3.70	2.24	1.69	5/8-11 x 3.94	M16	PS3-12"A(F)	410004	PS4-12"A(F)	410023
16	5.35	0.20	12.99	14.25	4.13	2.64	2.16	5/8-11 x 4.53	M16	PS3-16"A(F)	410005	PS4-16"A(F)	410024



## Universal Lathe Chucks & Accessories



### Spare Jaws for PS Series Universal

Hard jaws, supplied as supplement or as spares, must be ground on the chuck, otherwise centering accuracy does not conform the limits

#### Hard Top Jaws – 3-Piece Sets

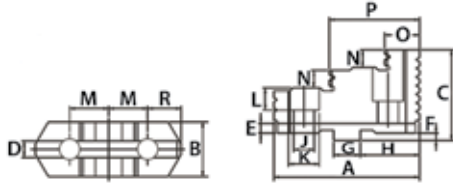

For Chuck Diameter (Inch)	B (Inch)	C (Inch)	D (Inch)	E (Inch)	F (Inch)	G (Inch)	H (Inch)	J (Inch)	K (Inch)	M (Inch)	N (Inch)	A OAL (Inch)	O (Inch)	P (Inch)	Weight (lbs)	Code
5	0.87	1.52	0.31	0.16	0.13	0.50	0.89	0.35	0.55	0.62	0.31	2.20	0.57	1.38	0.93	356303
6	0.98	1.63	0.31	0.16	0.13	0.50	1.12	0.43	0.67	0.75	0.33	2.64	0.81	1.69	1.20	410140
8	1.18	1.77	0.31	0.16	0.13	0.50	1.37	0.43	0.67	0.87	0.41	3.15	0.98	2.09	2.10	410141
10	1.42	2.09	0.50	0.16	0.13	0.75	1.56	0.55	0.79	1.06	0.53	3.74	1.14	2.52	3.20	410142
12	1.65	2.40	0.50	0.16	0.13	0.75	1.87	0.55	0.79	1.25	0.69	4.25	1.22	3.01	5.10	410143
16	1.77	2.76	0.50	0.16	0.25	0.75	2.25	0.71	1.00	1.50	0.69	5.00	1.85	3.46	7.30	410144
20	1.98	3.42	0.50	0.16	0.25	0.75	2.25	0.87	1.30	1.50	0.79	5.16	2.05	3.23	14.40	410145
25 & 32	2.05	3.42	0.50	0.16	0.25	0.75	2.25	0.87	1.30	1.50	0.79	5.16	2.05	3.23	27.10	356301

#### Hard Top Jaws – 4-Piece Sets

For Chuck Diameter (Inch)	B (Inch)	C (Inch)	D (Inch)	E (Inch)	F (Inch)	G (Inch)	H (Inch)	J (Inch)	K (Inch)	M (Inch)	N (Inch)	A OAL (Inch)	O (Inch)	P (Inch)	Weight (lbs)	Code
5	0.87	1.52	0.31	0.16	0.13	0.50	0.89	0.35	0.55	0.62	0.31	2.20	0.57	1.38	1.25	356303
6	0.98	1.63	0.31	0.16	0.13	0.50	1.12	0.43	0.67	0.75	0.33	2.64	0.81	1.69	1.60	356304
8	1.18	1.77	0.31	0.16	0.13	0.50	1.37	0.43	0.67	0.87	0.41	3.15	0.98	2.09	2.80	356305
10	1.42	2.09	0.50	0.16	0.13	0.75	1.56	0.55	0.79	1.06	0.53	3.74	1.14	2.52	4.27	356306
12	1.65	2.40	0.50	0.16	0.13	0.75	1.87	0.55	0.79	1.25	0.69	4.25	1.22	3.01	6.80	356307
16	1.77	2.76	0.50	0.16	0.25	0.75	2.25	0.71	1.00	1.50	0.69	5.00	1.85	3.46	9.74	356308
20	1.98	3.42	0.50	0.16	0.25	0.75	2.25	0.87	1.30	1.50	0.79	5.16	2.05	3.23	19.20	356309
25	2.05	3.42	0.50	0.16	0.25	0.75	2.25	0.87	1.30	1.50	0.79	5.16	2.05	3.23	36.20	356310

#### Soft Top Jaws – 1 Piece

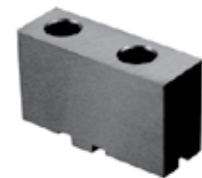
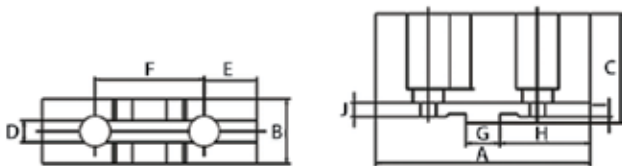

For Chuck Diameter (Inch)	A (Inch)	B (Inch)	C (Inch)	D (Inch)	E (Inch)	F (Inch)	G (Inch)	H (Inch)	I (Inch)	J (Inch)	M Thread	Weight (lbs)	Code
5	2.52	0.87	1.52	0.31	0.59	1.25	0.50	1.00	0.13	0.16	5/16-18	0.66	356314
6	3.07	1.00	1.63	0.31	0.84	1.50	0.50	1.34	0.13	0.16	3/8-16	1.01	410146
8	3.54	1.06	1.71	0.31	0.95	1.75	0.50	1.57	0.13	0.16	3/8-16	1.43	410147
10	4.17	1.28	2.03	0.50	1.08	2.12	0.75	1.77	0.13	0.16	1/2-13	2.54	410148
12	4.72	1.57	2.16	0.50	1.21	2.50	0.75	2.09	0.13	0.16	1/2-13	3.53	410149
16	5.51	1.65	2.54	0.50	1.35	3.00	0.75	2.48	0.25	0.16	5/8-11	4.85	410150
20	5.51	1.97	2.93	0.50	1.35	3.00	0.75	2.48	0.25	0.16	3/4-10	5.29	410151
25 & 32	6.30	2.05	3.29	0.50	1.35	3.00	0.75	2.48	0.25	0.16	3/4-10	9.26	411044

## Universal Lathe Chucks & Accessories



### Spare Jaws for PS Series Universal (continued)

Hard jaws, supplied as supplement or as spares, must be ground on the chuck, otherwise centering accuracy does not conform the limits

#### Hard Master Jaws – 3-Piece Sets

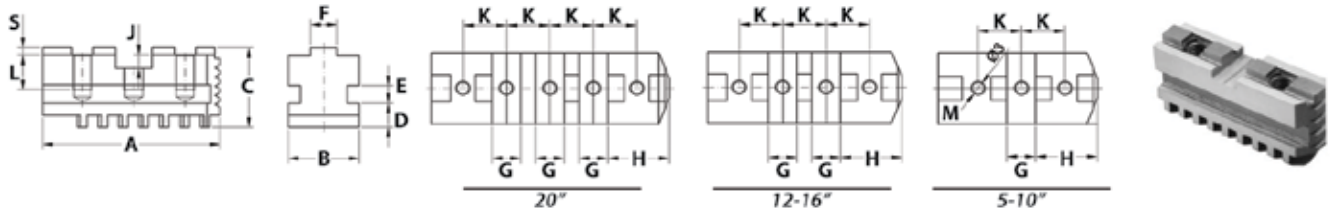

For Chuck Diameter (Inch)	B (Inch)	D (Inch)	E (Inch)	F (Inch)	G (Inch)	H (Inch)	J (Inch)	K (Inch)	L (Inch)	A OAL (Inch)	S (Inch)	M Thread	Weight (lbs)	Code
5	0.79	0.31	0.31	0.31	0.50	0.89	0.16	0.62	0.53	2.13	0.13	5/16-8	0.93	356311
6	0.79	0.31	0.31	0.31	0.50	1.12	0.16	0.75	0.55	2.56	0.13	3/8-16	1.20	410152
8	0.98	0.35	0.39	0.31	0.50	1.37	0.16	0.87	0.55	3.11	0.13	3/8-16	2.10	410153
10	1.10	0.43	0.47	0.50	0.75	1.56	0.16	1.06	0.63	3.62	0.13	1/2-13	3.20	410154
12	1.26	0.50	0.47	0.50	0.75	1.87	0.16	1.25	0.63	4.33	0.13	1/2-13	5.10	410155
16	1.42	0.59	0.55	0.50	0.75	2.25	0.28	1.50	0.87	5.12	0.13	5/8-11	7.30	410156
20	1.57	0.63	0.55	0.50	0.75	2.25	0.28	1.50	1.26	6.54	0.13	3/4-10	14.40	410157
25 & 32	1.97	0.63	0.55	0.50	0.75	2.25	0.28	1.50	1.26	8.27	0.13	3/4-10	27.10	356312

#### Hard Master Jaws – 4-Piece Sets

For Chuck Diameter (Inch)	B (Inch)	D (Inch)	E (Inch)	F (Inch)	G (Inch)	H (Inch)	J (Inch)	K (Inch)	L (Inch)	A OAL (Inch)	S (Inch)	M Thread	Weight (lbs)	Code
5	0.79	0.31	0.31	0.31	0.50	0.89	0.16	0.62	0.53	2.13	0.13	5/16-8	1.25	356315
6	0.79	0.31	0.31	0.31	0.50	1.12	0.16	0.75	0.55	2.56	0.13	3/8-16	1.60	356316
8	0.98	0.35	0.39	0.31	0.50	1.37	0.16	0.87	0.55	3.11	0.13	3/8-16	2.80	356317
10	1.10	0.43	0.47	0.50	0.75	1.56	0.16	1.06	0.63	3.62	0.13	1/2-13	4.27	356318
12	1.26	0.50	0.47	0.50	0.75	1.87	0.16	1.25	0.63	4.33	0.13	1/2-13	6.80	356319
16	1.42	0.59	0.55	0.50	0.75	2.25	0.28	1.50	0.87	5.12	0.13	5/8-11	9.74	356320
20	1.57	0.63	0.55	0.50	0.75	2.25	0.28	1.50	1.26	6.54	0.13	3/4-10	19.20	356321
25	1.97	0.63	0.55	0.50	0.75	2.25	0.28	1.50	1.26	8.27	0.13	3/4-10	36.20	356322

## Universal Lathe Chucks & Accessories



### Spare Parts for PS Series

#### Scroll Plates – 1 Piece



For Chuck Diameter (Inch)	Code
6.25	410116
8.00	410117
10.00	410118
12.50	410119
15.75	410120
20.00	410121

#### Keys – 1 Piece



For Chuck Diameter (Inch)	Code
6.25	410129
8.00	410129
10.00	410130
12.50	410131
15.75	410132
20.00	410133

#### Pinions – 1 Piece



For Chuck Diameter (Inch)	Code
6.25	410122
8.00	410123
10.00	410124
12.50	410125
15.75	410126
20.00	410127

#### Pinion Screws – 1 Piece



For Chuck Diameter (Inch)	Code
6.25	410134
8.00	410135
10.00	410136
12.50	410137
15.75	410138
20.00	410139

## Precision Lathe Chucks & Accessories



### PSL Series – Steel Body – Large Through Hole – 3-Jaw Self-Centering Chucks 2 Pc. Hard Reversible Jaws

- Forged steel body, plain back, medium duty
- 2-piece reversible American Standard tongue and groove jaws
- Designed for pipe machining or pipe welding cut-off operations
- Can be used on grinders, lathes, rotary tables, indexers and welding devices
- Jaws, scroll plate and three pinions are made of fine alloy steel, carefully heat-treated and ground
- Balanced scroll

**Each chuck is provide with:**

- 1 set of master jaws
- 1 set of hard top jaws
- 1 chuck wrench
- 1 set of mounting screws
- 2 hex keys
- 2 lifting eye bolts

**Optional spare parts:**

- Soft top jaws

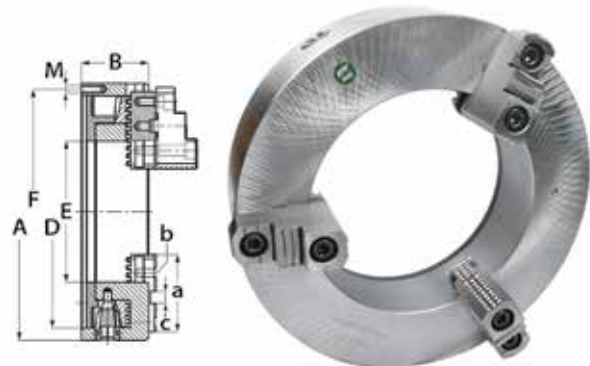

### Plain Back Mounting

**PSL Series - Plain Back Mounting Specifications**

Chuck Diameter (Inch)	RPM Max	Weight (lbs)	d1 Min-Max (Inch)	d2 Min-Max (Inch)	d3 Min-Max (Inch)	M Thread	Jaw Stroke Min-Max (Inch)	Weight of Workpiece without Support (lbs)	Weight of Workpiece with Support (lbs)
16	650	128	5.12 - 10.63	9.06 - 13.78	11.81 - 15.75	M12 x 40	6.61 - 11.34	110	3301
20	460	168	9.84 - 14.96	12.99 - 17.72	15.16 - 19.69	M16 x 40	9.87 - 14.96	177	5512
26	325	258	14.80 - 18.50	17.91 - 22.64	20.28 - 25.00	M16 x 40	14.80 - 19.57	265	7716
32	260	468	10.24 - 22.28	14.17 - 29.53	16.54 - 31.50	M24 x 160	7.40 - 22.28	441	8820

Chuck Diameter (Inch)	Model	a (Inch)	B (Inch)	b (Inch)	c (Inch)	D H7 (Inch)	F (Inch)	E Through Hole (Inch)	Code
16	PSL3-16"	4.72	4.13	5/8-11	0.75	14.25	15.00	8.66	410025
20	PSL3-20"	4.72	4.72	3/4-10	0.75	18.19	18.96	12.60	410026
26	PSL3-26"	5.00	5.32	3/4-10	0.75	22.83	24.41	15.98	356359
32	PSL3-32"	8.86	5.95	3/4-10	0.75	27.95	18.11	16.14	356360

### Spare Jaws for PSL Series

Hard jaws, supplied as supplement or as spares, must be ground on the chuck, otherwise centering accuracy does not conform the limits

### Hard Master Jaws – 3-Piece Set

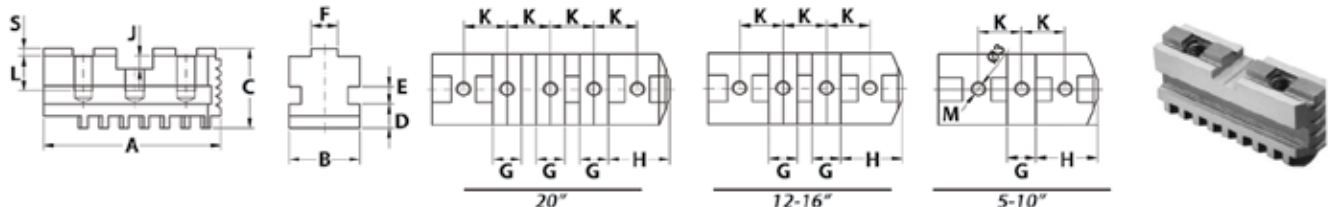

For Chuck Diameter (Inch)	B (Inch)	D (Inch)	E (Inch)	F (Inch)	G (Inch)	H (Inch)	J (Inch)	K (Inch)	L (Inch)	A OAL (Inch)	S (Inch)	Weight (lbs)	M Thread	Code
16	1.42	0.59	0.55	0.50	0.75	2.25	0.28	1.50	0.87	4.72	0.13	9.00	5/8-11	410166
20	1.57	0.63	0.55	0.50	0.75	2.25	0.28	1.50	1.28	4.72	0.13	10.10	3/4-10	410167
26	1.97	0.63	0.55	0.50	0.75	2.25	0.28	1.50	1.28	5.00	0.13	16.00	3/4-10	356371
32	1.97	0.63	0.55	0.50	0.75	2.25	0.28	1.50	1.28	8.86	0.13	28.00	3/4-10	356372

## Precision Lathe Chucks & Accessories



### Spare Jaws for PSL Series (continued)

Hard jaws, supplied as supplement or as spares, must be ground on the chuck, otherwise centering accuracy does not conform the limits

#### Hard Top Jaws – 3-Piece Sets

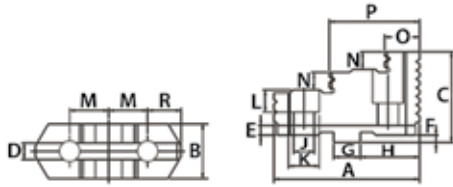

For Chuck Diameter (Inch)	B (Inch)	C (Inch)	D (Inch)	E (Inch)	F (Inch)	G (Inch)	H (Inch)	J (Inch)	K (Inch)	M (Inch)	N (Inch)	A OAL (Inch)	O (Inch)	P (Inch)	Weight (lbs)	Code
16	1.77	2.76	0.50	0.16	0.25	0.75	2.25	0.71	1.00	1.50	0.69	5.00	1.85	3.46	7.30	410144
20	1.98	3.42	0.50	0.16	0.25	0.75	2.25	0.87	1.30	1.50	0.79	5.16	2.05	3.23	14.40	410145
26 & 32	2.05	3.42	0.50	0.16	0.25	0.75	2.25	0.87	1.30	1.50	0.79	5.16	2.05	3.23	27.10	356302

#### Soft Top Jaws – 1-Piece

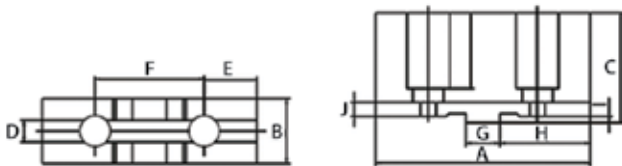

For Chuck Diameter (Inch)	A (Inch)	B (Inch)	C (Inch)	D (Inch)	E (Inch)	F (Inch)	G (Inch)	H (Inch)	I (Inch)	J (Inch)	Weight (lbs)	M Thread	Code
16	5.51	1.65	2.54	0.50	1.35	3.00	0.75	2.48	0.25	0.16	4.85	5/8-11	410150
20	5.51	1.97	2.93	0.50	1.35	3.00	0.75	2.48	0.25	0.16	5.29	3/4-10	410151
26 & 32	6.30	2.05	3.29	0.50	1.35	3.00	0.75	2.48	0.25	0.16	9.26	3/4-10	411044

#### Spare Parts for PSL Series

##### Scroll Plates – 1 Piece



For Chuck Diameter (Inch)	Code
15.75	410172
20.00	410173

##### Keys – 1 Piece



For Chuck Diameter (Inch)	Code
15.75	411012
20.00	411014

##### Pinions – 1 Piece



For Chuck Diameter (Inch)	Code
15.75	410174
20.00	410175

##### Pinion Screw – 1 Piece



For Chuck Diameter (Inch)	Code
20.00	411016

##### Mounting Bolts – 1 Piece



For Chuck Diameter (Inch)	Code
15.75	410179
20.00	410180

## Independent Lathe Chucks & Accessories



### PI Series – Semi-Steel Body – 4-Jaw Independent Chucks

#### Solid Reversible Jaws

- Semi-steel body, medium duty
- Designed to grip round or odd shaped workpieces
- Hard solid reversible jaws
- Chucks larger than 10" with T-slots

#### Each chuck is provided with:

- 1 set of hard solid reversible jaws
- 1 T- wrench
- 2 hex keys
- 1 set of mounting bolts
- 2 eye bolts for chucks larger than 10"

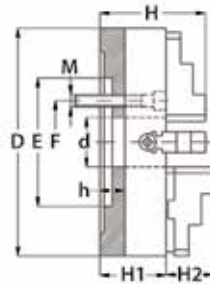

#### Plain Back Mounting

Chuck Diameter (Inch)	d Hole Diameter (Inch)	RPM Maximum	Model	E (Inch)	F (Inch)	H1 (Inch)	H2 (Inch)	H (Inch)	h	Code
8	2.20	2500	PI4-8"	2.95	3.74	2.95	0.24	4.33	0.24	410027
10	2.56	2000	PI4-10"	5.91	4.13	3.35	0.28	4.70	0.28	410028
12	3.15	1500	PI4-12"	6.89	5.25	3.74	0.28	5.70	0.28	410029
16	3.94	1000	PI4-16"	7.87	6.75	4.13	0.39	6.09	0.39	410031
20	4.92	700	PI4-20"	10.63	9.25	4.72	0.47	7.07	0.47	410032
25	6.30	500	PI4-25"	10.63	9.25	5.51	0.47	7.87	0.47	410033
32	8.27	300	PI4-32"	9.84	11.81	5.71	0.47	8.27	0.47	410034

#### Camlock Mounting

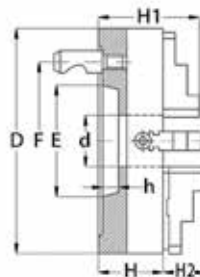

Chuck Diameter (Inch)	d Hole Diameter (Inch)	RPM Maximum	Model	E (Inch)	F (Inch)	H (Inch)	h (Inch)	H1 (Inch)	Taper Size	Code
8	2.20	2500	PI4-8"/D1-4	2.50	3.25	2.95	0.51	4.33	D1-4	410035
8	2.20	2500	PI4-8"/D1-5	3.25	4.13	2.95	0.59	4.33	D1-5	410036
10	2.36	2000	PI4-10"/D1-4	2.50	3.25	3.35	0.51	4.70	D1-4	410037
10	2.56	2000	PI4-10"/D1-5	3.25	4.13	3.35	0.59	4.70	D1-5	410038
10	2.56	2000	PI4-10"/D1-6	4.19	5.25	3.35	0.63	4.70	D1-6	410039
12	3.15	1500	PI4-12"/D1-6	4.19	5.25	3.74	0.63	5.70	D1-6	410040
12	3.15	1500	PI4-12"/D1-8	5.50	6.75	3.74	0.71	5.70	D1-8	410041
16	3.94	1000	PI4-15"/D1-6	4.19	5.25	4.13	0.63	6.09	D1-6	410042
16	3.94	1000	PI4-15"/D1-8	5.50	6.75	4.13	0.71	6.09	D1-8	410043
16	3.94	1000	PI4-15"/D1-11	7.75	9.25	4.13	0.79	6.09	D1-11	410044
20	4.92	700	PI4-20"/D1-8	5.50	6.75	4.72	0.71	7.07	D1-8	410045
20	4.92	700	PI4-20"/D1-11	7.75	9.25	4.72	0.79	7.07	D1-11	410046
25	6.30	500	PI4-25"/D1-11	7.75	9.25	5.51	0.79	7.87	D1-11	410047

## Independent Lathe Chucks & Accessories



### PI Series – Semi-Steel Body – 4-Jaw Independent Chucks (continued)

#### 2 Pc. Hard Reversible Jaws

- Semi-steel body, medium duty
- Designed to grip round or odd shaped workpieces
- 2-piece reversible ANSI tongue and groove jaws
- Chucks larger than 10" with T-slots

#### Each chuck is provided with:

- 1 set of 2-piece hard reversible jaws
- 1 T- wrench
- 2 hex keys
- 1 set of mounting bolts
- 2 eye bolts for chucks larger than 10"

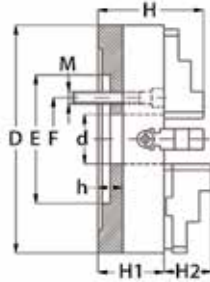

#### Plain Back Mounting

Chuck Diameter (Inch)	d Hole Diameter (Inch)	RPM Maximum	Model	E (Inch)	F (Inch)	Hole Enlargement (Inch)	H (Inch)	H1 (Inch)	H2 (Inch)	h (Inch)	Code
8	2.20	2500	PI4-8"A	2.95	3.74	2.28	2.95	1.83	1.83	0.24	410214
10	2.56	2000	PI4-10"A	5.91	4.13	2.65	3.35	2.38	2.38	0.28	410215
12	3.15	1500	PI4-12"A	6.89	5.25	3.86	3.74	2.40	2.40	0.28	410216
16	3.94	1000	PI4-16"A	7.87	6.75	4.62	4.13	2.85	2.85	0.39	410217
20	4.92	700	PI4-20"A	10.63	9.25	6.27	4.72	3.56	3.56	0.47	410218
25	6.30	500	PI4-25"A	10.63	9.25	7.09	5.51	3.85	3.85	0.47	410219

#### Camlock Mounting

Chuck Diameter (Inch)	d Hole Diameter (Inch)	RPM Maximum	Model	E (Inch)	F (Inch)	H2 (Inch)	H (Inch)	H1 (Inch)	h (Inch)	Bolt Thread	L Bolt	Code
8	2.20	1800	PI4-8"A/D1-4	2.50	3.25	1.83	2.95	0.51	0.62	M10 x 1.0	3	410200
8	2.20	1800	PI4-8"A/D1-5	3.25	4.13	1.83	2.95	0.59	0.75	M12 x 1.0	6	410201
10	2.36	1500	PI4-10"A/D1-4	2.50	3.25	2.38	3.35	0.51	0.62	M10 x 1.0	3	410202
10	2.56	1500	PI4-10"A/D1-5	3.25	4.13	2.38	3.35	0.59	0.75	M12 x 1.0	6	410203
10	2.56	1500	PI4-10"A/D1-6	4.19	5.25	2.38	3.35	0.63	0.87	M16 x 1.5	6	410204
12	3.15	1200	PI4-12"A/D1-6	4.19	5.25	2.40	3.74	0.63	0.87	M16 x 1.5	6	410205
12	3.15	1200	PI4-12"A/D1-8	5.50	6.75	2.40	3.74	0.71	1.00	M20 x 1.5	6	410206
16	3.94	800	PI4-15"A/D1-6	4.19	5.25	2.85	4.13	0.63	0.87	M16 x 1.5	6	410207
16	3.94	800	PI4-16"A/D1-8	5.50	6.75	2.85	4.13	0.71	1.00	M20 x 1.5	6	410208
16	3.94	800	PI4-16"A/D1-11	7.75	9.25	2.85	4.13	0.79	1.19	M22 x 1.5	6	410209
20	4.92	500	PI4-20"A/D1-8	5.50	6.75	3.56	4.72	0.71	1.00	M20 x 1.5	6	410210
20	4.92	500	PI4-20"A/D1-11	7.75	9.25	3.56	4.72	0.79	1.19	M22 x 1.5	6	410211
25	6.30	400	PI4-25"A/D1-11	7.75	9.25	3.85	5.51	0.79	1.19	M22 x 1.5	6	410212

## Independent Lathe Chucks & Accessories



### Spare Jaws for PI Series

Hard jaws, supplied as supplement or as spares, must be ground on the chuck, otherwise centering accuracy does not conform the limits

#### Hard Solid Reversible Jaws – 4-Piece Sets

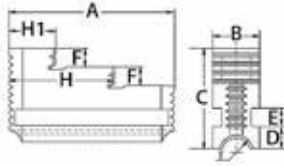

For Chuck Diameter (Inch)	A (Inch)	B (Inch)	C (Inch)	D (Inch)	E (Inch)	F (Inch)	H (Inch)	H1 (Inch)	Thread	Weight (lbs)	Code
8	3.35	1.06	2.42	0.45	0.39	0.47	2.28	1.20	24 x 4 sq.	1.54	411020
10	3.62	1.06	2.42	0.45	0.39	0.47	2.58	1.20	24 x 4 sq.	1.65	411022
12	4.37	1.57	3.01	0.38	0.47	0.71	2.64	1.06	Tr32 x 6	3.31	411024
16	5.08	1.57	3.01	0.38	0.47	0.71	3.09	1.28	Tr32 x 6	3.97	411026
20	6.00	2.05	3.68	0.46	0.59	0.87	3.66	1.39	Tr36 x 6	7.50	411028
25	6.97	2.05	3.96	0.62	0.71	0.98	4.29	1.77	Tr40 x 6	8.80	411030
32	7.95	2.76	4.51	0.62	0.79	0.98	4.80	1.73	Tr40 x 8	18.00	411032

#### Hard Top Jaws – 4-Piece Sets

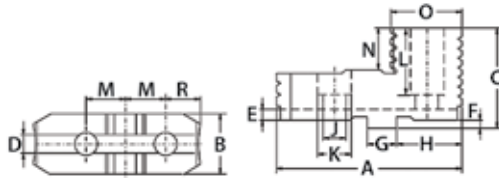

For Chuck Diameter (Inch)	B (Inch)	C (Inch)	D (Inch)	E (Inch)	F (Inch)	G (Inch)	H (Inch)	J (Inch)	K (Inch)	M (Inch)	N (Inch)	A OAL (Inch)	O (Inch)	P (Inch)	Weight (lbs)	Code
8	1.34	1.71	0.31	0.16	0.13	0.50	1.39	0.43	0.71	0.88	0.37	3.23	0.87	2.09	1.65	411048
10	1.34	2.03	0.50	0.16	0.13	0.75	1.57	0.55	0.79	1.03	0.47	3.80	0.98	2.44	2.25	411050
12	1.65	2.17	0.50	0.16	0.13	0.75	1.89	0.55	0.79	1.25	0.51	4.43	1.06	2.78	3.40	411052
16	1.65	2.54	0.50	0.16	0.25	0.75	2.26	0.71	1.02	1.50	0.53	5.08	1.04	3.11	4.50	411054
20	2.13	2.93	0.50	0.16	0.25	0.75	2.28	0.89	1.30	1.50	0.71	5.35	1.48	3.43	7.00	411056
25	2.13	3.23	0.50	0.16	0.25	0.75	2.28	0.89	1.30	1.50	0.83	5.35	1.48	3.43	7.60	411058
32	2.83	3.46	0.50	0.16	0.25	0.75	2.28	0.89	1.30	1.50	0.94	5.35	1.57	3.50	11.00	411060

#### Soft Top Jaws – 1-Piece

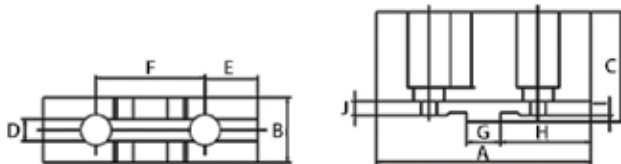

For Chuck Diameter (Inch)	A (Inch)	B (2) (Inch)	C (Inch)	D (Inch)	E (Inch)	F (Inch)	G (Inch)	H (Inch)	I (Inch)	J (Inch)	M Thread	Weight (lbs)	Code
8	3.54	1.06	1.71	0.31	0.95	1.75	0.50	1.57	0.13	0.28	3/8-16	1.43	411034
12	4.72	1.57	2.16	0.50	1.21	2.50	0.75	2.09	0.25	0.28	1/2-13	3.53	411038
25 & 32	6.30	2.05	3.29	0.50	1.35	3.00	0.75	2.48	0.25	0.41	3/4-10	9.26	411044



## Independent Lathe Chucks & Accessories



### Spare Jaws for PI Series

Hard jaws, supplied as supplement or as spares, must be ground on the chuck, otherwise centering accuracy does not conform the limits

#### Hard Master Jaws – 4-Piece Sets

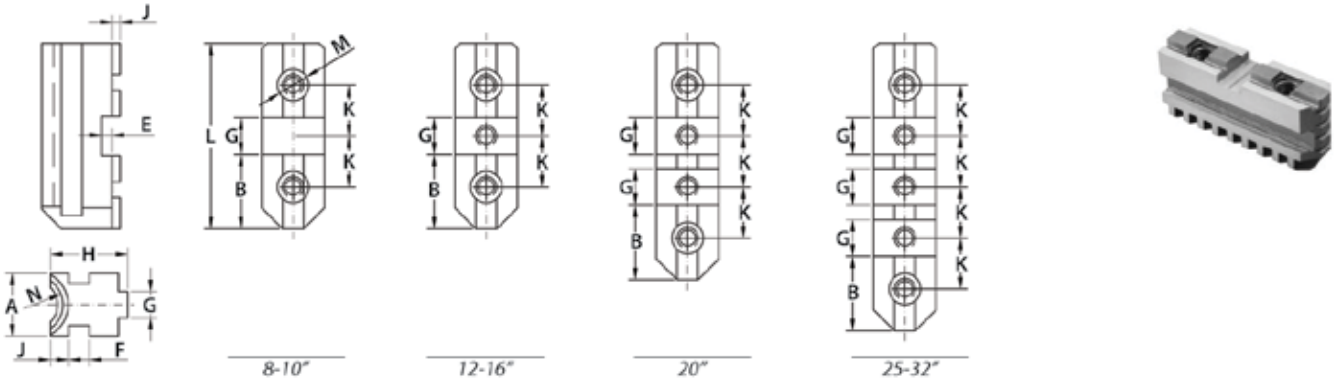

For Chuck Diameter (Inch)	A (Inch)	B (Inch)	C (Inch)	E (Inch)	F (Inch)	G (Inch)	H (Inch)	J (Inch)	K (Inch)	L (Inch)	N Thread	Weight (lbs)	M Thread	Code
8	1.06	1.31	0.50	0.16	0.39	0.31	1.26	0.45	0.88	3.11	24 x 4 sq.	1.00	3/8-16	411062
10	1.06	1.48	0.75	0.16	0.39	0.50	1.50	0.45	1.06	3.70	24 x 4 sq.	1.45	1/2-13	411064
12	1.57	1.79	0.75	0.16	0.47	0.50	1.54	0.38	1.25	4.33	Tr32 x 6	2.45	1/2-13	411066
16	1.57	5.16	0.75	0.28	0.47	0.50	1.73	0.38	1.50	5.08	Tr32 x 6	3.30	5/8-11	411068
20	2.05	2.18	0.75	0.28	0.59	0.50	2.32	0.46	1.50	6.61	Tr36 x 6	7.90	3/4-10	411070
25	2.05	2.18	0.75	0.28	0.71	0.50	2.32	0.62	1.50	8.11	Tr40 x 6	9.50	3/4-10	411072
32	2.76	2.18	0.75	0.28	0.79	0.50	2.32	0.62	1.50	8.11	Tr44 x 8	13.00	3/4-10	411074

### Spare Parts for PI Series

#### Operating Screws – 1 Piece



#### Keys – 1 Piece



#### Thrust Bearings – 1 Piece



For Chuck Diameter (Inch)	Code	For Chuck Diameter (Inch)	Code	For Chuck Diameter (Inch)	Code
8.00	411076	8.00	411104	8.00	411090
10.00	411078	10.00	411106	10.00	411092
12.50	411080	12.50	411108	12.50	411094
15.75	411082	15.75	411110	15.75	411096
20.00	411084	20.00	411112	20.00	411098
25.00	411086	25.00	411114	25.00	411100
32.00	411088	32.00	411116	32.00	411102

## Oil Country Lathe Chucks & Accessories



### PEO Series – Forged Steel Body – Large Through Hole – 3-Jaw Self-Centering Chucks

#### Heavy Duty Serrated Jaws

- Extra heavy duty
- ANSI standard tongue and groove jaws
- Master and top jaws provided with heavy duty serration for safe and superior gripping power
- Critical chuck surfaces precision ground and heat treated
- A2 mounts supplied
- Extra wide master jaws



Heavy Duty Serrated Jaws

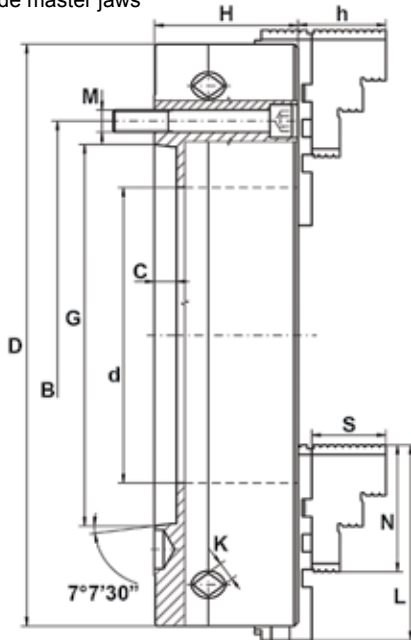

#### Specifications

Chuck Dia. (Inch)	Spindle Nose	Hard Top Jaw Width (Inch)	Hard Master Jaw Width (Inch)	Spindle Mounting Bolts	Top Jaw Mounting Bolts	*Load Capacity (lbs)	Clamping Capacity Min - Max (Inch)
20	A2-11	2.36	2.36	M20 x 2.5	3/4-10	5200	1.77 - 19.68
20	A2-15	2.36	2.36	M24 x 3.0	3/4-10	5200	1.77 - 19.68
25	A2-15	3.54	3.15	M24 x 3.0	7/8-9	7800	3.15 - 24.80
25	A2-20	3.54	3.15	M24 x 3.0	7/8-9	7800	6.30 - 24.80
32	A2-15	3.54	3.15	M24 x 3.0	7/8-9	10400	5.12 - 31.50
32	A2-20	3.54	3.15	M24 x 3.0	7/8-9	10400	7.09 - 31.50

\*For supported workpieces only

#### Type A2 Mounting

Chuck Diameter (Inch)	d Hole Diameter (Inch)	Spindle Nose Size	B (Inch)	G (Inch)	H (Inch)	h (Inch)	C (Inch)	S (Inch)	N (Inch)	K (Inch)	L (Inch)	RPM Maximum	Weight (lbs)	Code
20	7.48	A2-11	9.25	7.75	4.68	3.42	0.75	2.98	5.31	0.75	6.54	1000	560	410080
20	8.00	A2-15	13.00	11.25	4.68	3.42	0.81	2.98	5.31	0.78	6.54	1000	530	410081
25	10.75	A2-15	13.00	11.25	6.06	3.64	0.81	3.29	5.31	0.87	8.86	850	650	410082
25	12.55	A2-20	18.25	16.25	6.06	3.64	0.87	3.29	5.31	0.87	8.86	850	620	410083
32	10.75	A2-15	13.00	11.25	6.30	3.64	0.81	3.29	5.31	0.87	8.86	600	1200	410084
32	12.55	A2-20	18.25	16.25	6.30	3.64	0.94	3.29	5.31	0.87	8.86	600	1170	410085

## Oil Country Lathe Chucks & Accessories



### Spare Jaws for PEO Series

Hard jaws, supplied as supplement or as spares, must be ground on the chuck, otherwise centering accuracy does not conform the limits

#### Heavy Duty Serrated Hard Top Jaws – 1-Piece

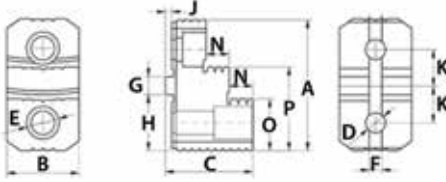

For Chuck Diameter (Inch)	A (Inch)	B (Inch)	C (Inch)	D (Inch)	E (Inch)	F (Inch)	G (Inch)	H (Inch)	J (Inch)	K (Inch)	N (Inch)	O (Inch)	P (Inch)	Code
20	5.34	2.56	3.23	0.87	1.30	0.50	0.75	2.25	0.25	1.50	0.83	2.05	3.37	356325
25 & 32	5.34	2.56	3.82	0.94	1.38	0.50	0.75	2.25	0.25	1.50	1.10	2.05	3.37	356326

#### Heavy Duty Serrated Hard Master Jaws – 1-Piece

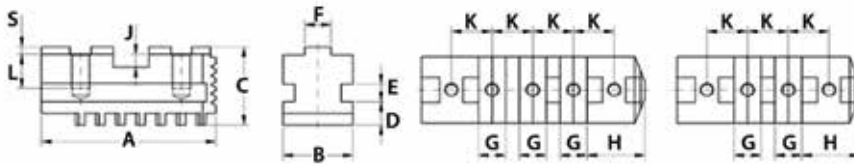

For Chuck Diameter (Inch)	A (Inch)	B (Inch)	C (Inch)	D (Inch)	E (Inch)	F (Inch)	G (Inch)	H (Inch)	J (Inch)	K (Inch)	L (Inch)	S (Inch)	M Thread	Code
20	6.54	2.36	2.56	0.79	0.79	0.49	0.75	2.25	0.28	1.50	1.42	0.13	3/4-10	356327
25 & 32	8.86	3.15	2.56	0.98	0.98	0.49	0.75	2.25	0.28	1.50	1.30	0.13	7/8-9	356328

# Oil Country Lathe Chucks & Accessories

## PEI Series – Forged Steel Body – Large Through Hole – 4-Jaw Independent Chucks

### Heavy Duty Serrated Jaws

- Extra heavy duty
- ANSI standard tongue and groove jaws
- Critical chuck surfaces are precision ground and heat treated
- Extra heavy duty master jaws and top jaws provided with heavy duty serration for safe and superior gripping power
- Extra heavy duty operating screws and thrust bearings
- A2 mounts supplied
- Induction hardened guide ways and through hole
- High accuracy



Heavy Duty Serrated Jaws

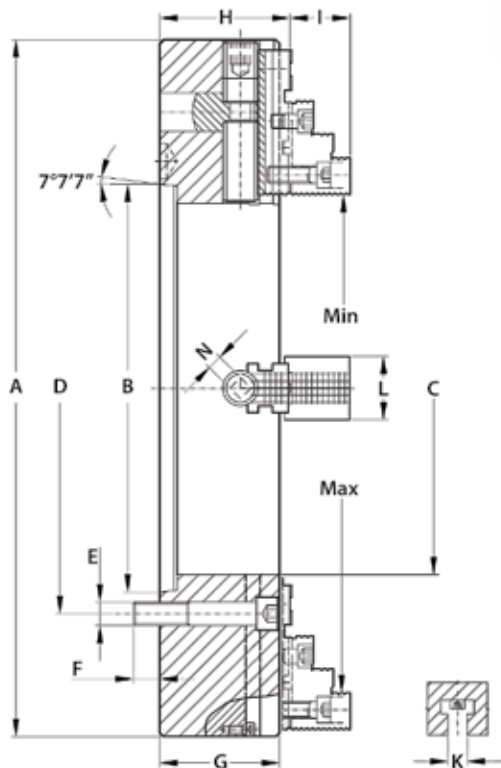

#### Specifications

Chuck Dia. (Inch)	Spindle Nose	Top Jaw Mounting Bolts	Operating Screw Thread	Clamping Capacity Min-Max
20	A2-11	3/4-10	Tr 44x8 LH	1.77 - 19.68
20	A2-15	3/4-10	Tr 44x8 LH	1.77 - 19.68
25	A2-15	7/8-9	Tr 50x8 LH	1.97 - 24.80
25	A2-20	7/8-9	Tr 50x8 LH	7.09 - 24.80
28	A2-15	7/8-9	Tr 50x8 LH	2.95 - 27.95
28	A2-20	7/8-9	Tr 50x8 LH	7.09 - 24.80
32	A2-15	7/8-9	Tr 50x8 LH	5.12 - 31.50
32	A2-20	7/8-9	Tr 50x8 LH	7.09 - 31.50
40	A2-28	7/8-9	Tr 50x8 LH	13.73 - 39.40

### Type A2 Mounting

Chuck Dia. (Inch)	C Through Hole (Inch)	Spindle Nose Size	B (Inch)	D (Inch)	G (Inch)	H (Inch)	I (Inch)	K (Inch)	L (Inch)	N (Inch)	E	F (Inch)	RPM Maximum	Weight (lbs)	Code
20	6.50	A2-11	7.75	9.25	5.71	6.07	2.98	0.87	2.36	0.75	M20 x 2.5	1.12	1000	450	410086
20	8.00	A2-15	11.25	13.00	5.71	6.07	2.98	0.87	2.36	0.75	M24 x 3.0	1.34	1000	414	410087
25	10.50	A2-15	11.25	13.00	6.10	6.07	3.57	0.87	2.96	0.87	M24 x 3.0	1.34	850	682	410088
25	12.55	A2-20	16.25	18.25	6.10	6.58	3.57	0.87	2.95	0.87	M24 x 3.0	1.50	850	649	410089
28	10.50	A2-15	11.25	13.00	6.10	6.58	3.57	0.87	2.95	0.87	M24 x 3.0	1.34	750	913	410090
28	12.55	A2-20	16.25	18.25	6.10	6.58	3.57	0.87	2.95	0.87	M24 x 3.0	1.50	750	869	410091
32	10.50	A2-15	11.25	13.00	6.50	6.97	3.57	0.87	2.95	0.87	M24 x 3.0	1.34	600	1287	410092
32	12.55	A2-20	16.25	18.25	6.50	6.97	3.57	0.87	2.95	0.87	M24 x 3.0	1.50	600	1243	410093
40	20.86	A2-28	23.00	25.50	6.89	7.37	3.57	1.10	2.95	0.87	M30 x 3.5	1.53	430	1683	410094

## Oil Country Lathe Chucks & Accessories



### Spare Jaws for PEI Series

Hard jaws, supplied as supplement or as spares, must be ground on the chuck, otherwise centering accuracy does not conform the limits

#### Heavy Duty Serrated Hard Top Jaws – 1-Piece

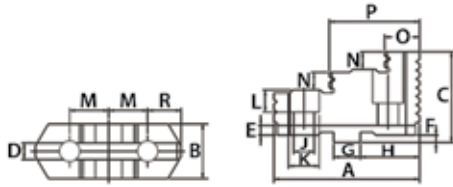

For Chuck Diameter (Inch)	B (Inch)	C (Inch)	D (Inch)	E (Inch)	F (Inch)	G (Inch)	H (Inch)	J (Inch)	K (Inch)	M (Inch)	N (Inch)	A OAL (Inch)	O (Inch)	P (Inch)	Weight (lbs)	Code
*25, 28 & 32	2.95	3.82	0.50	0.16	0.24	0.75	2.25	0.95	1.38	1.50	1.10	5.34	2.05	3.37	12.50	356334
20	2.36	3.23	0.50	0.16	0.24	0.75	2.25	0.87	1.30	1.50	0.83	5.38	2.05	3.37	9.00	356329
40	3.35	4.21	0.50	0.16	0.24	0.75	2.25	0.95	1.38	1.50	1.18	6.30	2.36	3.74	18.50	356330

\* Except 25" chuck with A2-15 spindle

#### Heavy Duty Serrated Hard Master Jaws – 1-Piece

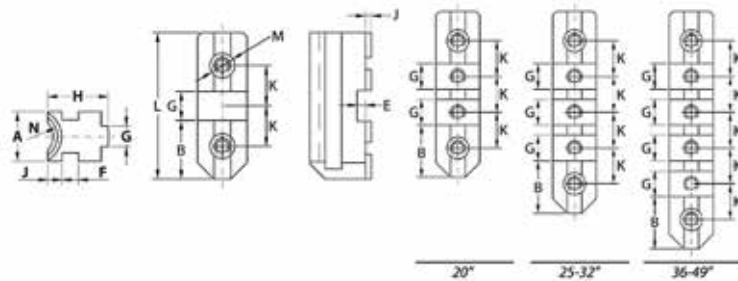

For Chuck Diameter (Inch)	A (Inch)	B (Inch)	C (Inch)	E (Inch)	F (Inch)	G (Inch)	H (Inch)	J (Inch)	K (Inch)	N (Inch)	L OAL (Inch)	M Thread	Weight (lbs)	Code
20	2.05	2.25	0.75	0.28	0.79	0.50	2.32	0.62	1.50	Tr44 x 8	6.69	3/4-10	8.50	356331
25, 28 & 32	2.76	2.25	0.75	0.28	0.79	0.50	2.47	0.62	1.50	Tr50 x 8	8.19	7/8-9	13.50	356332
40	3.15	2.25	0.75	0.28	0.98	0.50	3.04	0.98	1.50	Tr55 x 8	11.81	7/8-9	30.00	356333

## Lathe Chuck Accessories



### Chuck Mounting Bolts For Hard & Soft Top Jaws

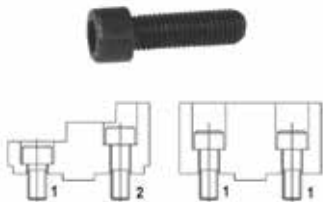

Specifications	Chuck Diameter	
	Bolt 1 Short	Bolt 2 Long
200	3/8" – 16 x 30mm	3/8" – 16 x 20mm
250	1/2" – 13 x 40mm	1/2" – 13 x 25mm
315	1/2" – 13 x 40mm	1/2" – 13 x 25mm
400	5/8" – 11 x 45mm	5/8" – 11 x 30mm
500	3/4" – 10 x 55mm	3/4" – 10 x 40mm
630	3/4" – 10 x 60mm	3/4" – 10 x 40mm
800	3/4" – 10 x 65mm	3/4" – 10 x 40mm

For Chuck Diameter (mm)	Thread	Bolt 1 Short – 1-Piece		Bolt 2 Long – 1-Piece	
		Length (mm)	Code	Length (mm)	Code
125	M8	20	411118	25	411120
160	M10	20	410158	30	410162
200	M10	20	410158	30	410162
250	M12	25	410159	40	410163
315	M12	25	410159	40	410163
400	M16	30	410160	45	410164
500	M20	40	410161	75	410165
630	M20	40	410161	80	410165

## 5C Collet Chucks

For Mounting with Back Plate

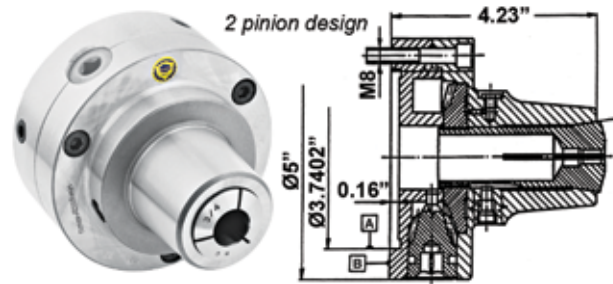

### Plain Back

### Direct Mount

### Machined Back Plates

Chuck Size	5C Collet Holding (Inch)	Weight (lbs)	Code
5	1/16 – 1-1/8	13.0	358031

Chuck Size	Mount	Weight (lbs)	Code
5	D1-4	15	358033
5	D1-5	15	358034

Taper Size	Code
D1-3	355565
D1-4	355566
D1-6	358038
L00	358039

Other back plates available

## Face Plate Jaws

For Radial T-Slot Tables



Front view



Back view

- Heavy semi-steel body
- Hard solid reversible jaws
- Each set of jaws furnished with mounting bolts (M18) and wrench
- Sold in 4-piece sets

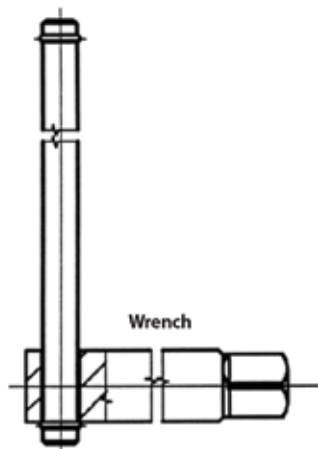

Wrench

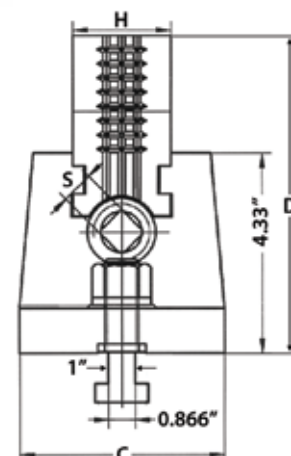
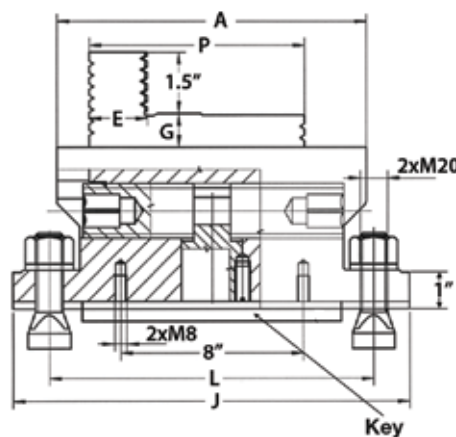

Jaw Size (Inch)	A (Inch)	C (Inch)	D (Inch)	E (Inch)	G (Inch)	H (Inch)	J (Inch)	L (Inch)	P (Inch)	S (Inch)	Weight (lbs)	Code
6	6	5.12	6.5	1.34	0.5	1.575	10.25	8	5	0.5551	149	355983
8	8	5.5	7	1.5	0.85	2.047	12.2	10	6	0.669	205	355984

## Chuck Stop Sets Standard & Deluxe



- The Royal Chuck Stop provides a simple, consistent method for locating short parts in a 3-jaw lathe chuck
- Captive, web-shaped design eliminates the danger of using spacers or parallels that could come loose and be thrown from a spinning chuck
- Three strong magnets further secure the stop to the chuck face
- Stop allows short parts to project past the chuck jaws, providing clearance for facing operations
- Setup time is greatly reduced - no need to bore soft jaws
- Very accurate - front and back locating surfaces are parallel within  $\pm 0.0004$ "
- Slot width can be easily enlarged to accommodate wider chuck jaws
- Anodized finish provides good wear-resistance



Description	Code
3-Piece Standard Set - 15, 20 and 25mm stops	355985
5-Piece Deluxe Set - 15, 20, 25, 30 and 35mm stops	355986

## Tool Posts, Turrets, Holders & Bushings

### 40-Position Tool Posts

**REPEATABILITY:** Guaranteed repeatability of index accuracy is 0.01mm and remains unchanged even after innumerable tool changes

**TECHNICAL DATA:** When determining the size, the following is important:

1. Driving motor power
2. Center height from carriage "X"
3. Length of tool holder "lg" should possibly correspond to width "z" of top slide
4. Height of tool "D", which together with height "y" and the space that remains underneath makes up the necessary size "X" (See table)

Example for choice of size: Driving power of machine – 6 KW. Width of carriage "Z", 145 mm, then use tool holder turret "B" and tool holders BD 25120, BD 25140, BD 32140 with BH 32130 and BJ 40120

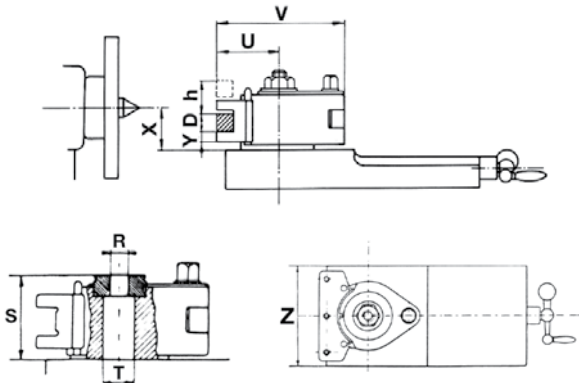

Minimum dimension "X" required for height of tool "D"

Type GS-	Aa	A	E	B	C	D1	D2
Toolholder D	12	16	20	16	20	25	25
Tool Height D	12	16	20	25	32	32	40
	12	16	20	25	32	32	40
	16	19	19	19	22		
	18	21	21	21	24	25	26
	23	23	23	23	26	27	28
	25	25	25	25	28	29	30
	29	32	33	34	35	35	38
	37	38	39	40	40	43	45
	44	45	45	48	50	51	52
	47	47	50	52	53	54	52
	55	58	60	61	62	60	65
						71	72
							70
							75
							85
							88

Hole "R" in the centring disc must be enlarged up to the size of the clamping screw

Original Wechselfix		Aa	A	E	B	C	D1	D2
Driving Power	KW	1	2	2	4.5	4.5	4.5	7
Change Toolholder Size	D	12	16	20	16	20	25	25
Width of Carriage Max.	Z mm	80	100	100	120	120	120	150
Center Height from Carriage Max.	X mm	Y+D	Y+D	Y+D	Y+D	Y+D	Y+D	Y+D
Center Height from Carriage Max.	X mm	X+h	X+h	X+h	X+h	X+h	X+h	X+h
Change Toolholder Size	h mm	8	11	11	16	11	6	20
Tool Repose	Y mm	6	8.5	8.5	8.5	8.5	12	12
Maximum Height of Tool	D mm	12	16	20	16	20	25	25
Total Width	V mm	70	100	100	125	125	125	150
Total Height	S mm	37	56	56	68	68	68	79
Maximum Throat	U mm	30	48	48	60	60	60	71
Boring Diameter	T mm	13	19.5	19.5	19.5	19.5	19.5	31.5

## Tool Posts, Turrets, Holders & Bushings

### 40-Position Tool Posts (continued)

#### Turrets, Holders & Bushings

Turret		Tool Holder D				Round Bar Holder H				Bush Holder J				*Part-Off Tool Holder A		Morse Taper Bushing L				
Type GS	Code	Type	D (mm)	lg (mm)	Code	Type	H (mm)	lg (mm)	Code	Type	J (mm)	lg (mm)	Code	Type	Code	Type	MT	lg (mm)	Code	
0-Aa	137001	AaD	12	50	137011	AaH	12	50	137101	AaJ	15	50	137201	AaT	137301	-	-	-	-	-
		-	-	-	-	AH	20	85	137102	AJ	30	80	137202	AT	137302	AL	1	30	137902	
1-A	137002	AD	16	90	137022	-	-	-	-	-	-	-	-	-	-	AL	2	40	137912	
		AD	20	75	137032	-	-	-	-	-	-	-	-	-	-	-	-	-	-	-
		AD	20	90	137042	-	-	-	-	-	-	-	-	-	-	-	-	-	-	-
		-	-	-	-	EH	16	100	137103	EJ	30	100	137203	ET	137303	AL	2	30	137913	
1-E	137003	ED	20	100	137023	EH	25	100	137113	EJ	40	100	137213	-	-	BL	3	40	137924	
		ED	25	100	137033	-	-	-	-	-	-	-	-	-	-	-	-	-	-	-
		BD	25	120	137014	BH	32	130	137104	BJ	40	120	137204	BT	137304	BL	1	40	137904	
2-B	137004	BD	25	140	137024	-	-	-	-	-	-	-	-	-	-	BL	2	40	137914	
		BD	32	120	137034	-	-	-	-	-	-	-	-	-	-	BL	3	40	137924	
		BD	32	140	137044	-	-	-	-	-	-	-	-	-	-	BL	4	40	137934	
		CD	32	150	137015	CH	40	160	137105	CJ	40	160	137205	CT	137305	-	-	-	-	
3-C	137005	CD	32	170	137025	CH	50	160	137115	CJ	50	160	137215	-	-	-	-	-	-	-
		CD	40	150	137035	-	-	-	-	-	-	-	-	-	-	-	-	-	-	-
		CD	40	170	137045	-	-	-	-	-	-	-	-	-	-	CL	3	50	137925	
		CD	45	170	137055	-	-	-	-	-	-	-	-	-	-	CL	4	50	137933	
4-D1	137006	D1D	40	180	137016	D1H	63	180	137106	D1J	63	180	137206	-	-	-	-	-	-	
		D1D	50	180	137026	-	-	-	-	-	-	-	-	-	-	DL1	5	63	137906	
		D1D	63	180	137036	-	-	-	-	-	-	-	-	-	-	-	-	-	-	
5-D2	137007	D2D	50	220	137017	D2H	70	220	137107	D2J	63	220	137207	-	-	DL2	5	63	137907	
		D2D	65	220	137027	-	-	-	-	-	-	-	-	-	-	-	-	-	-	

\*Blades not included with Part-Off Tool Holder A

### Quick Change 40-Position Tool Posts



- Adjust tool to 40 different positions indicated by a marked position dial (index every 9°)
- Fully interchangeable with other brands of 40-position quick change tool posts and holders
- Heat-treated and precision-ground for very accurate repeatability
- Change tools in seconds
- Allows adjustment of height of cutting edge easily and accurately

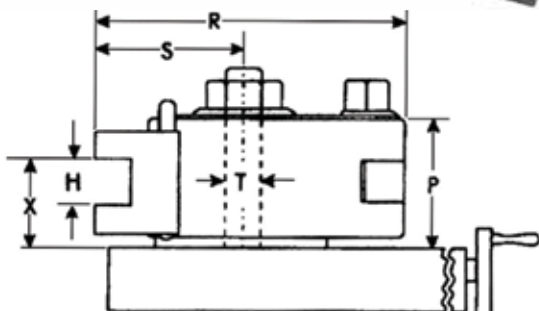

Tool Post Size	A	E	B	C	D
Lathe Swing	6 - 13	10 - 18	13 - 20	18 - 30	25 - 36
Max. Driving Power (hp)	3	6	9	18	30
R Max.	4.13	5.14	6.00	7.90	9.52
S Max.	2.07	2.57	2.95	3.62	4.88
P	1.83	2.30	2.68	3.90	4.80
T	0.79	0.79	1.26	1.57	1.57
H	0.83	0.75	1.00	1.25	1.50
X Minimum	1.18	1.37	1.46	1.86	2.36
X Maximum	1.61	2.04	2.25	3.43	3.74



## Tool Posts, Turrets, Holders & Bushings

### Quick Change 40-Position Tool Posts (continued)

#### Turrets, Holders & Bushings

Turret		Turn & Face Holder D			Boring Bar Holder B			Bushing Holder S			Morse Taper Bushing L		
Type	Code	D (mm)	lg (mm)	Code	H Max (mm)	lg	Code	J Bore (mm)	lg	Code	Outside Diameter (mm)	Inside Diameter MT	Code
A	*302900	20	90	*302901	20	90	*302902	30	80	302904	30	1	302905
E	*302910	20	100	302914	30	100	*302912	30	100	302915	30	2	302917
		25	100	*302911	—	—	—	40	100	302916	40	3	302918
B	*302920	25	120	*302921	32	130	*302922	40	120	302925	40	3	302926
		32	120	302924	—	—	—	—	—	—	40	4	302927
C	*302930	32	150	*302931	32	160	*302932	40	150	302937	40	3	302939
		40	150	302934	40	160	302936	50	150	302938	40	4	302898
		40	170	302935	—	—	—	—	—	—	50	4	302899
D	*302890	40	180	*302891	50	180	*302894	—	—	—	—	—	—
		50	180	302892	63	180	302895	63	180	302896	63	5	302897
		63	180	302893	—	—	—	—	—	—	—	—	—

\*Items included in sets below

#### Quick Change 40-Position Tool Post Sets

Sets Include: 1 turret, 3 turn and face holders, 1 boring bar holder, 1 'T' wrench and 1 lock wrench

Type	Description	Weight (kg)	Code
A	Turret – 302900, Turn and Face Holder – 302901, Boring Bar Holder – 302902	4	302903
E	Turret – 302910, Turn and Face Holder – 302911, Boring Bar Holder – 302912	10	302913
B	Turret – 302920, Turn and Face Holder – 302921, Boring Bar Holder – 302922	13	302923
C	Turret – 302930, Turn and Face Holder – 302931, Boring Bar Holder – 302932	25	302933
D	Turret – 302890, Turn and Face Holder – 302891, Boring Bar Holder – 302894	44	302889

#### Quick Change Tool Post Sets

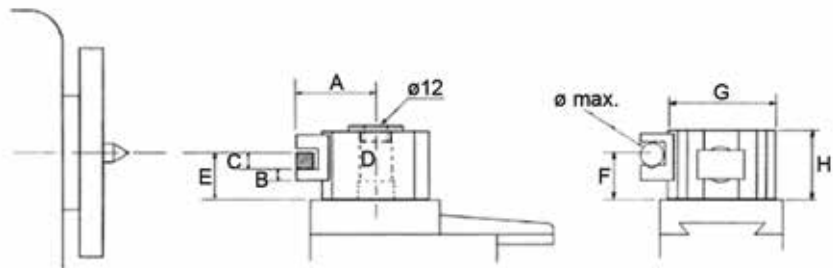



















Sets include: 1 turret, 4 flat section tool holders, 1 V-slotted tool holder, 1 elbow wrench, 1 cross-pin spanner

Model	Swing of Lathe (Inch)	A (Inch)	B (Inch)	C (Inch)	D (Inch)	E Min-Max (Inch)	F Min-Max (Inch)	Bar Maximum Diameter (Inch)	Morse Taper	H (Inch)	I (Inch)	A Cut-Off Blade Min-Max (Inch)	B Cut-Off Blade Min-Max (Inch)	Code
M-O	10	4.40	0.31	0.63	0.551	0.95-1.30	0.79-1.18	0.59	1	1.77	2.75	0.08-0.16	0.39-0.59	145001
A-O	14	6.00	0.47	0.83	0.787	1.26-1.65	1.00-1.38	0.75	2	2.36	4.00	0.08-0.20	0.47-0.79	145003
B-O	18	8.00	0.59	1.30	0.984	1.89-2.60	1.50-2.20	1.00	3	3.35	5.00	0.08-0.20	0.59-1.00	145005
C-O	24	8.50	0.71	1.42	1.259	2.20-3.07	1.57-2.44	1.00	4	3.75	5.75	0.12-0.25	0.70-1.18	145006
D-O	Over 24	11.00	0.83	1.65	1.654	2.50-3.66	1.77-2.95	1.34	5	4.72	7.00	0.15-0.31	0.70-1.38	145007
E-O	Over 24	12.25	0.87	2.00	1.654	3.00-4.12	2.28-3.54	1.34	5	5.12	8.00	0.19-0.39	1.00-1.50	145008

# Tool Posts, Turrets, Holders & Bushings

## Quick Change Tool Posts (continued)

### Accessories

<p><b>QUICK CHANGE TOOL HOLDER ACCESSORIES</b></p> <p><i>For Models M-O, A-O, B-O, C-O, D-O, E-O</i></p>	 <p><b>201 Tool Holders</b></p>	 <p><b>202 V-Slot Tool Holders</b></p>	 <p><b>203 Morse Cone Tool Holders</b></p>	
	 <p><b>217 Part-Off Holders</b></p>	 <p><b>204 Eccentric Pins</b></p>	 <p><b>205 Tenons</b></p>	 <p><b>206 Height Adjustment Reels</b></p>
	 <p><b>207 Extractors</b></p>	 <p><b>208 Long Screws</b></p>	 <p><b>209 Short Screws</b></p>	 <p><b>210 Set Screws</b></p>
	 <p><b>211 Extractor Screws</b></p>	 <p><b>212 Springs</b></p>	 <p><b>213 Pins</b></p>	 <p><b>214 Elbow Wrenches</b></p>
	 <p><b>215 Cross-Pin Spanners</b></p>	 <p><b>218 Screws</b></p>	 <p><b>219 Clamps for Part-Off Blades</b></p>	 <p><b>220 Clamp Screws</b></p>

Model	For Model	Code	Model	For Model	Code	Model	For Model	Code	Model	For Model	Code	Model	For Model	Code
Turret	M-O	145100	203	D-O	145703	206	B-O	145506	210	C-O	145610	214	C-O	145614
Turret	A-O	145300	203	E-O	145803	206	C-O	145606	210	D-O	145710	214	D-O	145714
Turret	B-O	145500	217	M-O	145117	206	D-O	145706	210	E-O	145810	214	E-O	145814
Turret	C-O	145600	217	A-O	145317	206	E-O	145806	211	M-O	145111	215	M-O	145115
Turret	D-O	145700	217	B-O	145517	207	M-O	145107	211	A-O	145311	215	A-O	145315
Turret	E-O	145800	217	C-O	145617	207	A-O	145307	211	B-O	145511	215	B-O	145515
201	M-O	145101	217	D-O	145717	207	B-O	145507	211	C-O	145611	215	C-O	145615
201	A-O	145301	217	E-O	145817	207	C-O	145607	212	M-O	145112	215	D-O	145715
201	B-O	145501	204	M-O	145104	208	M-O	145108	212	A-O	145312	215	E-O	145815
201	C-O	145601	204	A-O	145304	208	A-O	145308	212	B-O	145512	218	D-O	145718
201	D-O	145701	204	B-O	145504	208	B-O	145508	212	C-O	145612	219	M-O	145119
201	E-O	145801	204	C-O	145604	208	C-O	145608	212	D-O	145712	219	A-O	145319
202	M-O	145102	204	D-O	145704	208	D-O	145708	212	E-O	145812	219	B-O	145519
202	A-O	145302	204	E-O	145804	208	E-O	145808	213	M-O	145113	219	C-O	145619
202	B-O	145502	205	M-O	145105	209	M-O	145109	213	A-O	145313	219	D-O	145719
202	C-O	145602	205	A-O	145305	209	A-O	145309	213	B-O	145513	219	E-O	145819
202	D-O	145702	205	B-O	145505	209	B-O	145509	213	C-O	145613	220	M-O	145120
202	E-O	145802	205	C-O	145605	209	C-O	145609	213	D-O	145713	220	A-O	145320
203	M-O	145103	205	D-O	145705	209	D-O	145709	213	E-O	145813	220	B-O	145520
203	A-O	145303	205	E-O	145805	210	M-O	145110	214	M-O	145114	220	C-O	145620
203	B-O	145503	206	M-O	145106	210	A-O	145310	214	A-O	145314	220	D-O	145720
203	C-O	145603	206	A-O	145306	210	B-O	145510	214	B-O	145514	220	E-O	145820

## Tool Posts & Holders

### Piston Type

#### Turrets



- All working parts hardened and ground
- Maximum rigidity for chatter-free performance
- No time wasted with shims - A knurled nut on each tool holder provides for exact height adjustment, entirely eliminating the use of shims
- Speed up your lathe operations by 90%
- Completely sealed for maintenance-free operation
- Cuts set-up time - Instant changing from one operation to another. You simply flip the handle and slide out the tool holder, then slide in the next holder with the locked-in tool bit in the exact pre-set position, ready to run. Set-ups can be made on a bench or surface plate, avoiding costly down-time
- Fits Aloris and Yuasa

**Turning:** The unequalled rigidity of this tool post and tool holders ensures smoother turning without chatter or vibration

**Drilling:** Enables you to drill by power feed with your carriage instead of hand operation of tail stock and easily centered

#### Turning & Facing Holder

##### No. 1 – Turning



Takes various sizes of bits. Turning and facing tools can be locked in together. Saves time and labor when changing operations.

#### Boring, Turning & Facing Holder

##### No. 2 – with V-Groove



“V” groove holds round shank boring bars and tools as well as square tool bits

#### Heavy Duty Boring Bar Holders

##### No. 4 & 41 (Larger Capacity)



For smaller diameter boring bars. Equipped with a split bushing to accommodate a boring bar of small diameter. It grips the bar with extreme rigidity, cuts smoothly without chatter.

#### Morse Taper Tool Holders

##### MT No. 2, 3, 4 & 5



Drills with carriage by using power feed, instead of tail stock. Easily centered. For No. 2, 3 and 4 Morse Taper Drills.

#### Universal Parting Blade Holders

##### No. 7



For bevel as well as T-cut blades. Enables you to cut-off close to chuck. Reduces vibration and prevents breaking blades.

#### Knurling, Facing & Turning Holders

##### No. 10



For turning and facing as well as knurling. Supplied with a set of high speed precision ground and tapped medium diamond knurls. Easily replaceable.

Description	12" Swing		10"-15" Swing		13"-18" Swing		14"-20" Swing	
	Tool Capacity	Code	Tool Capacity	Code	Tool Capacity	Code	Tool Capacity	Code
Turret	–	303100	–	303200	–	303300	–	303400
No. 1 Turning	1/2" square	303101	5/8" square	303201	3/4" square	303301	1" square	303401
No. 2 Boring "V"	7/16" diameter	303102	5/8" diameter	303202	3/4" diameter	303302	1" diameter	303402
No. 4 Boring (Bush)	5/8" diameter	303104	3/4" diameter	303204	3/4" diameter	303304	1" diameter	303404
No. 41 Boring (Bush)	3/4" diameter	303141	1" diameter	303241	1" diameter	303341	1-1/4" diameter	303441
MT 2 & 3 Morse Taper	MT2	303105	MT2	303205	MT3	303305	MT3	303405
MT 4 & 5 Morse Taper	MT3	303153	MT3	303253	MT4	303353	MT4	303453
No. 7 Part-Off	1/2"	303107	11/16"	303207	3/4"	303307	7/8"	303407
No. 10 Knurl	–	303110	–	303210	–	303310	–	303410

## CNC Bar Pullers



### Compact CNC Bar Pullers

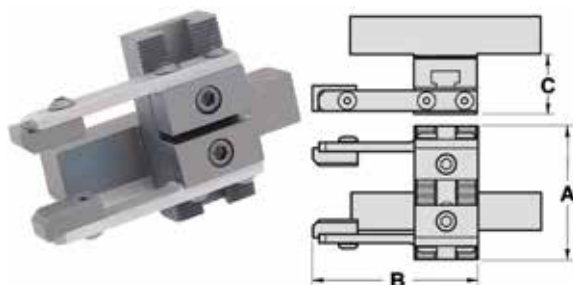

- Great for use with small CNC lathes - compact design minimizes tool interference
- Very easy to setup and use
- Unit can pull round, square, and hex stock
- Flexible heat-treated steel fingers provide strong gripping force
- Each compact bar puller includes one set of serrated jaws and one blank spindle bushing

Order insert holder and insert separately. Additional sizes and shank styles are available. Please contact your KAR distributor for information.

Shank Size (Inch)	Gripping Range (Inch)	A (Inch)	B (Inch)	C (Inch)	Code
1/2 sq.	1/8 – 1-5/8	2-1/8	3-1/4	1-3/16	217050
3/4 sq.	1/8 – 2-1/4	2-5/8	3-1/4	1-3/16	217051
1 sq.	1/8 – 2-1/4	2-5/8	3-1/4	1-3/16	217052
1 sq.	1/8 – 3	3-5/8	3-1/4	1-3/16	217053

### Heavy Duty CNC Bar Pullers

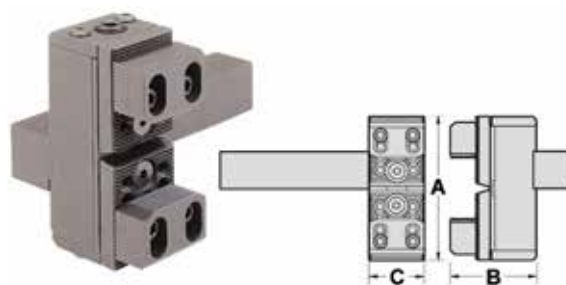

- Gripping range from 1/8" to 6-1/2" (extra capacity jaws sold separately)
- Gripping force is easily adjusted by altering spring pressure
- Jaws have two gripping surfaces: one side is serrated for increased gripping power, the other side is smooth to help prevent marking
- Smooth side is also used when pulling small diameter stock
- Very easy to set up and use
- Each unit comes with one set of standard jaws and one blank spindle bushing

Shank Size (Inch)	Gripping Range		A (Inch)	B (Inch)	C (Inch)	Code
	Standard Jaws (Inch)	Extra Capacity Jaws (Inch)				
3/4 sq.	1/8 – 2-1/4	1-7/8 – 3-3/4	3-7/8	2-9/16	1-1/2	217058
1 sq.	1/8 – 2-1/4	1-7/8 – 3-3/4	3-7/8	2-9/16	1-1/2	217059
1 sq.	1/8 – 3-1/2	1-7/8 – 5-3/8	4-3/4	2-9/16	1-1/2	217060
1 sq.	1/8 – 3-5/8	1-7/8 – 5-1/2	5	2-3/4	1-3/4	217061
1 sq.	1/8 – 4-7/8	1-7/8 – 6-1/2	6-3/4	2-3/4	1-3/4	217062

### Combination CNC Cut-Off/Bar Pullers

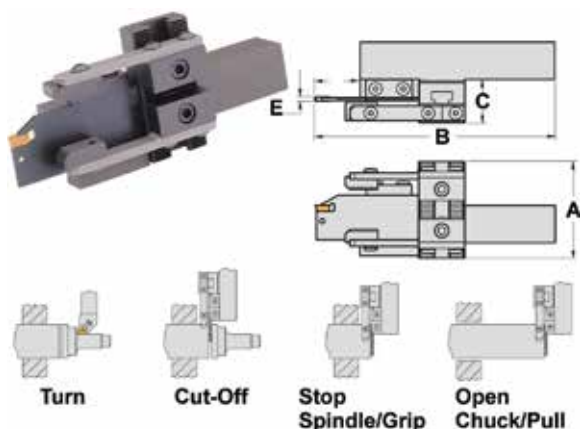

- Combination bar puller/cut-off tool saves a turret station by combining two tools into one
- Benefits include reduced indexing, reduced set-up time, and reduced cycle time
- Compact design - good for all CNC machines where tool interference is a problem
- Gripping range from 1/8" to 2-1/4"
- Flexible heat-treated steel fingers provide strong gripping force
- Unit easily handles round, square, and hex stock
- Very easy to set up and use
- Includes bar puller, one set of standard jaws and one blank spindle bushing

Order holder and insert separately

Shank Size (Inch)	Gripping Range (Inch)	A (Inch)	B (Inch)	C (Inch)	D (Inch)	E (Inch)	Code
3/4 sq.	1/8 – 2-1/4	2-5/8	4-3/4	1-3/16	7/8	0.125	217054
1 sq.	1/8 – 2-1/4	2-5/8	6-3/8	1-3/16	1-1/4	0.125	217055

### Part-Off Blade & Insert



Bar puller accepts many popular brands of holders – must be slightly modified

Bar Puller Shank Size (Inch)	Code
1/2 or 3/4	217056
1	217057

## Expanding Mandrels



Model	Range (mm)	Range (Inch)	Length (mm)	Length (Inch)	Diameter (mm)	Diameter (Inch)	I (mm)	I (Inch)	Complete	Sleeve Only
									Code	Code
LM-1	13 – 19	0.51 – 0.75	165	6.5	11	0.43	40	1.57	165101	165201
LM-2	19 – 25	0.75 – 1.00	196	7.7	13	0.50	60	2.36	165102	165202
LM-3	25 – 33	1.00 – 1.30	257	10.0	17	0.67	90	3.54	165103	165203
LM-4	33 – 42	1.30 – 1.66	297	11.7	23	0.91	120	4.72	165104	165204
LM-5	42 – 52	1.66 – 2.05	338	13.3	30	1.18	130	5.12	165105	165205
LM-6	52 – 65	2.05 – 2.56	392	15.4	38	1.50	150	5.90	165106	165206
LM-7	65 – 78	2.56 – 3.07	392	15.4	38	1.50	150	5.90	165107	165207
LM-8	78 – 90	3.07 – 3.55	392	15.4	38	1.50	150	5.90	165108	165208

Model	Set Range (Inch)	Code
SET: LM-16	0.51 – 2.56 (Model LM-1 to LM-6)	165116



## Revolving Tail Stock Turrets

- Compact, accurate and well-made, these revolving tailstock turrets convert your engine or bench lathe into a screw machine
- Available in two sizes, have six holes each for holding six tools
- Trigger type handle is conveniently located which enables instant changing from one tool to another
- Supplied with Morse taper shank as indicated below

Turret Diameter (Inch)	Hole Size (Inch)	Morse Taper	Weight (lbs)	Code
2-1/2	5/8	2	4	303500
5	1	3	12	303501
5	1	4	12	303502
5	1	1" SS	12	303503

## Tool Holder Bushings



### CNC Bushings – Black Oxide Finish – Types C, CV, B, DD, J & Z

- For use on all NC and CNC turning machines to adapt a wide variety of boring bars, drills, reamers and other round shank type tools
- Heat treated and precision ground

#### Type C

- C bushings have long slots for clamping directly on the tool for positive alignment of the cutting edge of the tool

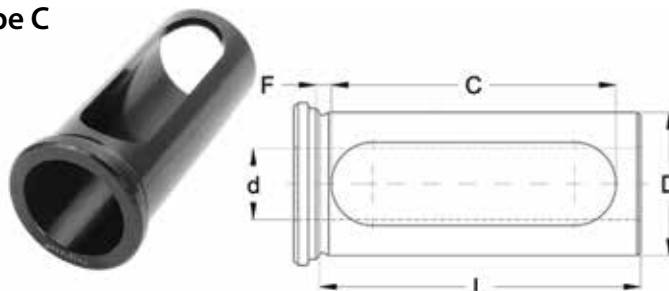

D Outside Diameter (Inch)	d Inside Diameter (Inch)	L Length Under Head (Inch)	C Slot Length (Inch)	F (Inch)	Code	D Outside Diameter (Inch)	d Inside Diameter (Inch)	L Length Under Head (Inch)	C Slot Length (Inch)	F (Inch)	Code	
3/4	3/8	2	1-1/2	0.1693	310732	1	3/4	2-3/4	2-3/8	0.1319	310540	
3/4	1/2	2	1-1/2	0.1693	310733	<b>4 Piece Set – 3/8" to 3/4"</b>					<b>300851</b>	
<b>2 Piece Set – 3/8" to 1/2"</b>						<b>300850</b>	1-1/4	3/8	3-1/4	2-3/4	0.1496	310544
1	3/8	2-3/4	2-3/8	0.1319	310534	1-1/4	1/2	3-1/4	2-3/4	0.1496	310545	
1	1/2	2-3/4	2-3/8	0.1319	310536	1-1/4	5/8	3-1/4	2-3/4	0.1496	310547	
1	5/8	2-3/4	2-3/8	0.1319	310538	1-1/4	3/4	3-1/4	2-3/4	0.1496	310549	

## Tool Holder Bushings



CNC Bushings – Black Oxide Finish – Types C, CV, B, DD, J &amp; Z (continued)

## Type C (continued)

D Outside Diameter (Inch)	d Inside Diameter (Inch)	L Length Under Head (Inch)	C Slot Length (Inch)	F (Inch)	Code	D Outside Diameter (Inch)	d Inside Diameter (Inch)	L Length Under Head (Inch)	C Slot Length (Inch)	F (Inch)	Code
1-1/4	7/8	3-1/4	2-3/4	0.1496	310734	2	5/8	4	3-5/8	0.1319	310596
1-1/4	1	3-1/4	2-3/4	0.1496	310553	2	3/4	4	3-5/8	0.1319	310597
<b>6 Piece Set – 3/8" to 1"</b>					<b>300852</b>	2	7/8	4	3-5/8	0.1319	310738
1-1/2	3/8	3-3/8	3	0.1260	310735	2	1	4	3-5/8	0.1319	310599
1-1/2	1/2	3-3/8	3	0.1260	310559	2	1-1/4	4	3-5/8	0.1319	310601
1-1/2	5/8	3-3/8	3	0.1260	310561	2	1-1/2	4	3-5/8	0.1319	310603
1-1/2	3/4	3-3/8	3	0.1260	310563	2	1-3/4	4	3-5/8	0.1319	310605
1-1/2	7/8	3-3/8	3	0.1260	310736	<b>8 Piece Set – 1/2" to 1-3/4"</b>					<b>300855</b>
1-1/2	1	3-3/8	3	0.1260	310567	2-1/2	1/2	4-1/2	4-1/8	0.1457	310739
1-1/2	1-1/4	3-3/8	3	0.1260	310571	2-1/2	5/8	4-1/2	4-1/8	0.1457	310740
<b>7 Piece Set – 3/8" to 1-1/4"</b>					<b>300853</b>	2-1/2	3/4	4-1/2	4-1/8	0.1457	310741
1-3/4	1/2	3-1/2	3-1/8	0.1260	310575	2-1/2	7/8	4-1/2	4-1/8	0.1457	310742
1-3/4	5/8	3-1/2	3-1/8	0.1260	310577	2-1/2	1	4-1/2	4-1/8	0.1457	310743
1-3/4	3/4	3-1/2	3-1/8	0.1260	310579	2-1/2	1-1/4	4-1/2	4-1/8	0.1457	310744
1-3/4	7/8	3-1/2	3-1/8	0.1260	310737	2-1/2	1-1/2	4-1/2	4-1/8	0.1457	310745
1-3/4	1	3-1/2	3-1/8	0.1260	310583	2-1/2	1-3/4	4-1/2	4-1/8	0.1457	310746
1-3/4	1-1/4	3-1/2	3-1/8	0.1260	310587	2-1/2	2	4-1/2	4-1/8	0.1457	310747
1-3/4	1-1/2	3-1/2	3-1/8	0.1260	310591	2-1/2	2-1/4	4-1/2	4-1/8	0.1457	310748
<b>7 Piece Set – 1/2" to 1-1/2"</b>					<b>300854</b>	<b>10 Piece Set – 1/2" to 2-1/4"</b>					<b>300856</b>
2	1/2	4	3-5/8	0.1319	310595						

## Type CV

- CV bushings have long slots for clamping directly on the tool for positive alignment of the cutting edge of the tool

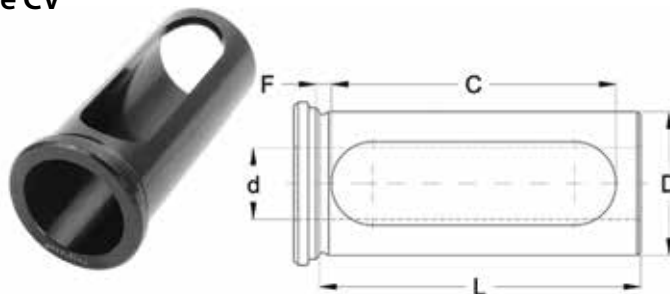

D Outside Diameter (Inch)	d Inside Diameter (Inch)	L Length Under Head Inch (mm)	C Slot Length Inch (mm)	F (Inch)	Code	D Outside Diameter (Inch)	d Inside Diameter (Inch)	L Length Under Head Inch (mm)	C Slot Length Inch (mm)	F (Inch)	Code
1-1/4	1/4	2.36 (60)	1.97 (50)	0.1535	310749	1-1/2	1/4	2.76 (70)	2.36 (60)	0.1575	310756
1-1/4	3/8	2.36 (60)	1.97 (50)	0.1535	310750	1-1/2	3/8	2.76 (70)	2.36 (60)	0.1575	310757
1-1/4	1/2	2.36 (60)	1.97 (50)	0.1535	310751	1-1/2	1/2	2.76 (70)	2.36 (60)	0.1575	310758
1-1/4	5/8	2.36 (60)	1.97 (50)	0.1535	310752	1-1/2	5/8	2.76 (70)	2.36 (60)	0.1575	310759
1-1/4	3/4	2.36 (60)	1.97 (50)	0.1535	310753	1-1/2	3/4	2.76 (70)	2.36 (60)	0.1575	310760
1-1/4	7/8	2.36 (60)	1.97 (50)	0.1535	310754	1-1/2	7/8	2.76 (70)	2.36 (60)	0.1575	310761
1-1/4	1	2.36 (60)	1.97 (50)	0.1535	310755	1-1/2	1	2.76 (70)	2.36 (60)	0.1575	310762
<b>7 Piece Set – 1/4" to 1"</b>					<b>300857</b>	1-1/2	1-1/4	70	60	0.1575	310763
						<b>8 Piece Set – 1/4" to 1-1/4"</b>					<b>300858</b>

## Tool Holder Bushings



CNC Bushings – Black Oxide Finish – Types C, CV, B, DD, J & Z (continued)

### Type B

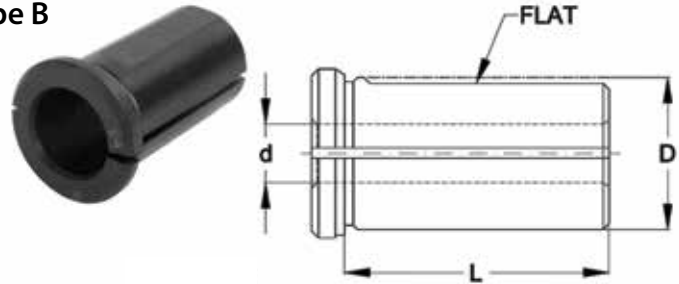

- B bushings have splits and flats providing strong gripping of the tool shanks

D Outside Diameter (Inch)	d Inside Diameter (Inch)	L Length Under Head (Inch)	Code
1	1/2	1-3/4	310832
1	5/8	1-3/4	310833
1	3/4	1-3/4	310834
<b>3 Piece Set – 1/2" to 3/4"</b>			<b>300844</b>
1-1/4	3/8	2-1/8	310700
1-1/4	1/2	2-1/8	310835
1-1/4	5/8	2-1/8	310701
1-1/4	3/4	2-1/8	310836
1-1/4	7/8	2-1/8	310702
1-1/4	1	2-1/8	310837
<b>6 Piece Set – 3/8" to 1"</b>			<b>300845</b>
1-1/2	3/8	2-1/2	310703
1-1/2	1/2	2-1/2	310838
1-1/2	5/8	2-1/2	310704
1-1/2	3/4	2-1/2	310839
1-1/2	7/8	2-1/2	310705
1-1/2	1	2-1/2	310840
1-1/2	1-1/4	2-1/2	310706
<b>7 Piece Set – 3/8" to 1-1/4"</b>			<b>300846</b>
1-3/4	1/2	3	310707
1-3/4	5/8	3	310708
1-3/4	3/4	3	310709
1-3/4	7/8	3	310710
1-3/4	1	3	310711

D Outside Diameter (Inch)	d Inside Diameter (Inch)	L Length Under Head (Inch)	Code
1-3/4	1-1/4	3	310712
1-3/4	1-1/2	3	310713
<b>7 Piece Set – 1/2" to 1-1/2"</b>			<b>300847</b>
2	1/2	3-1/2	310714
2	5/8	3-1/2	310715
2	3/4	3-1/2	310716
2	7/8	3-1/2	310717
2	1	3-1/2	310718
2	1-1/4	3-1/2	310719
2	1-1/2	3-1/2	310720
2	1-3/4	3-1/2	310721
<b>8 Piece Set – 1/2" to 1-3/4"</b>			<b>300848</b>
2-1/2	1/2	4	310722
2-1/2	5/8	4	310723
2-1/2	3/4	4	310724
2-1/2	7/8	4	310725
2-1/2	1	4	310726
2-1/2	1-1/4	4	310727
2-1/2	1-1/2	4	310728
2-1/2	1-3/4	4	310729
2-1/2	2	4	310730
2-1/2	2-1/4	4	310731
<b>10 Piece Set – 1/2" to 2-1/4"</b>			<b>300849</b>

### Type DD

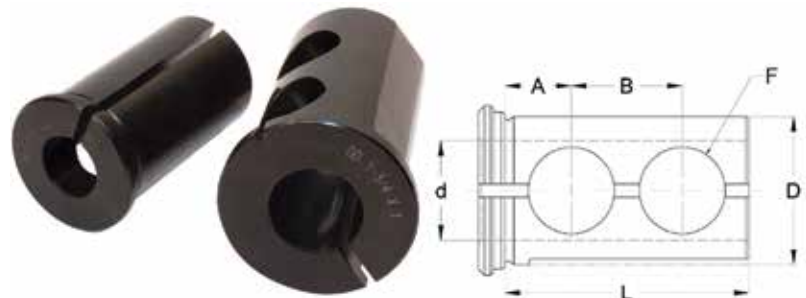

- DD bushings combine Type B split bushings and Type J with the set screw holes allowing this bushing to be used as either Type B or Type J
- Each bushing has a split, two or four holes and a flat

D Outside Diameter (Inch)	d Inside Diameter (Inch)	L Length Under Head (Inch)	A (Inch)	B (Inch)	F (Inch)	Code
1-1/2	3/8	2-1/2	11/16	1-1/8	7/8	310779
1-1/2	1/2	2-1/2	11/16	1-1/8	7/8	310780

D Outside Diameter (Inch)	d Inside Diameter (Inch)	L Length Under Head (Inch)	A (Inch)	B (Inch)	F (Inch)	Code
1-1/2	5/8	2-1/2	11/16	1-1/8	7/8	310781
1-1/2	3/4	2-1/2	11/16	1-1/8	7/8	310782



## Tool Holder Bushings

CNC Bushings – Black Oxide Finish – Types C, CV, B, DD, J & Z (continued)

### Type DD (continued)

D Outside Diameter (Inch)	d Inside Diameter (Inch)	L Length Under Head (Inch)	A (Inch)	B (Inch)	F (Inch)	Code	D Outside Diameter (Inch)	d Inside Diameter (Inch)	L Length Under Head (Inch)	A (Inch)	B (Inch)	F (Inch)	Code
1-1/2	7/8	2-1/2	11/16	1-1/8	7/8	310783	2-1/2	7/8	4	7/8	1-3/4	1-1/4	310802
1-1/2	1	2-1/2	11/16	1-1/8	7/8	310784	2-1/2	1	4	7/8	1-3/4	1-1/4	310803
1-1/2	1-1/4	2-1/2	11/16	1-1/8	7/8	310785	2-1/2	1-1/4	4	7/8	1-3/4	1-1/4	310804
<b>7 Piece Set – 3/8" to 1-1/4"</b>						<b>300859</b>	2-1/2	1-1/2	4	7/8	1-3/4	1-1/4	310805
1-3/4	1/2	3	3/4	1-1/4	7/8	310786	2-1/2	1-3/4	4	7/8	1-3/4	1-1/4	310806
1-3/4	5/8	3	3/4	1-1/4	7/8	310787	2-1/2	2	4	7/8	1-3/4	1-1/4	310807
1-3/4	3/4	3	3/4	1-1/4	7/8	310788	2-1/2	2-1/4	4	7/8	1-3/4	1-1/4	300862
1-3/4	7/8	3	3/4	1-1/4	7/8	310789	<b>8 Piece Set – 3/4" to 2-1/4"</b>						<b>300863</b>
1-3/4	1	3	3/4	1-1/4	7/8	310790	3	1	4-1/2	1	2	1-1/4	300864
1-3/4	1-1/4	3	3/4	1-1/4	7/8	310791	3	1-1/4	4-1/2	1	2	1-1/4	300865
1-3/4	1-1/2	3	3/4	1-1/4	7/8	310792	3	1-1/2	4-1/2	1	2	1-1/4	300866
<b>7 Piece Set – 1/2" to 1-1/2"</b>						<b>300860</b>	3	1-3/4	4-1/2	1	2	1-1/4	300867
2	1/2	3-1/2	3/4	1-1/2	1	310793	3	2	4-1/2	1	2	1-1/4	300868
2	5/8	3-1/2	3/4	1-1/2	1	310794	3	2-1/4	4-1/2	1	2	1-1/4	300869
2	3/4	3-1/2	3/4	1-1/2	1	310795	<b>6 Piece Set – 1" to 2-1/4"</b>						<b>300670</b>
2	7/8	3-1/2	3/4	1-1/2	1	310796	3-1/2	1-1/2	5-1/4	1-1/4	2-1/2	1-1/4	300671
2	1	3-1/2	3/4	1-1/2	1	310797	3-1/2	1-3/4	5-1/4	1-1/4	2-1/2	1-1/4	300672
2	1-1/4	3-1/2	3/4	1-1/2	1	310798	3-1/2	2	5-1/4	1-1/4	2-1/2	1-1/4	300873
2	1-1/2	3-1/2	3/4	1-1/2	1	310799	3-1/2	2-1/4	5-1/4	1-1/4	2-1/2	1-1/4	300874
2	1-3/4	3-1/2	3/4	1-1/2	1	310800	3-1/2	2-1/2	5-1/4	1-1/4	2-1/2	1-1/4	300875
<b>8 Piece Set – 1/2" to 1-3/4"</b>						<b>300861</b>	3-1/2	3	5-1/4	1-1/4	2-1/2	1-1/4	300876
2-1/2	3/4	4	7/8	1-3/4	1-1/4	310801	<b>6 Piece Set – 1-1/2" to 3"</b>						<b>300877</b>

### Type J

- J bushings have a long solid body with two holes for clamping directly on the tool with set screws for positive alignment of the cutting edge of the tool

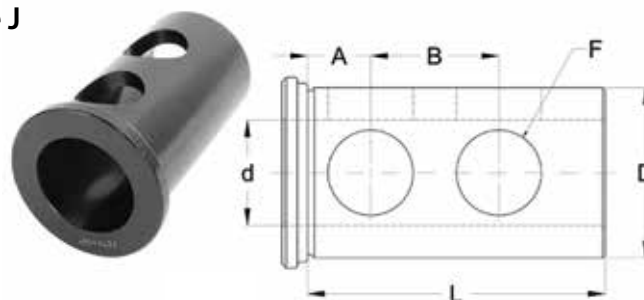

D Outside Diameter (Inch)	d Inside Diameter (Inch)	L Length Under Head (Inch)	A (Inch)	B (Inch)	F Hole Diameter (Inch)	Code	D Outside Diameter (Inch)	d Inside Diameter (Inch)	L Length Under Head (Inch)	A (Inch)	B (Inch)	F Hole Diameter (Inch)	Code
1	1/2	1-3/4	7/16	7/8	5/8	310418	1-1/2	3/4	2-1/2	11/16	1-1/8	7/8	310455
1	5/8	1-3/4	7/16	7/8	5/8	310420	1-1/2	7/8	2-1/2	11/16	1-1/8	7/8	310766
1	3/4	1-3/4	7/16	7/8	5/8	310422	1-1/2	1	2-1/2	11/16	1-1/8	7/8	310459
<b>3 Piece Set – 1/2" to 3/4"</b>						<b>300878</b>	1-1/2	1-1/4	2-1/2	11/16	1-1/8	7/8	310463
1-1/4	3/8	2-1/8	5/8	1	3/4	310436	<b>7 Piece Set – 3/8" to 1-1/4"</b>						<b>300880</b>
1-1/4	1/2	2-1/8	5/8	1	3/4	310437	1-3/4	1/2	3	3/4	1-1/4	7/8	310470
1-1/4	5/8	2-1/8	5/8	1	3/4	310440	1-3/4	5/8	3	3/4	1-1/4	7/8	310472
1-1/4	3/4	2-1/8	5/8	1	3/4	310441	1-3/4	3/4	3	3/4	1-1/4	7/8	310474
1-1/4	7/8	2-1/8	5/8	1	3/4	310764	1-3/4	7/8	3	3/4	1-1/4	7/8	310767
1-1/4	1	2-1/8	5/8	1	3/4	310445	1-3/4	1	3	3/4	1-1/4	7/8	310478
<b>6 Piece Set – 3/8" to 1"</b>						<b>300879</b>	1-3/4	1-1/4	3	3/4	1-1/4	7/8	310482
1-1/2	3/8	2-1/2	11/16	1-1/8	7/8	310765	1-3/4	1-1/2	3	3/4	1-1/4	7/8	310486
1-1/2	1/2	2-1/2	11/16	1-1/8	7/8	310451	<b>7 Piece Set – 1/2" to 1-1/2"</b>						<b>300881</b>
1-1/2	5/8	2-1/2	11/16	1-1/8	7/8	310453	2	1/2	3-1/2	3/4	1-1/2	1	310490



## Tool Holder Bushings



CNC Bushings – Black Oxide Finish – Types C, CV, B, DD, J & Z (continued)

### Type J (continued)

D Outside Diameter (Inch)	d Inside Diameter (Inch)	L Length Under Head (Inch)	A (Inch)	B (Inch)	F Hole Diameter (Inch)	Code	D Outside Diameter (Inch)	d Inside Diameter (Inch)	L Length Under Head (Inch)	A (Inch)	B (Inch)	F Hole Diameter (Inch)	Code
2	5/8	3-1/2	3/4	1-1/2	1	310491	2-1/2	3/4	4	7/8	1-3/4	1-1/4	310771
2	3/4	3-1/2	3/4	1-1/2	1	310492	2-1/2	7/8	4	7/8	1-3/4	1-1/4	310772
2	7/8	3-1/2	3/4	1-1/2	1	310768	2-1/2	1	4	7/8	1-3/4	1-1/4	310773
2	1	3-1/2	3/4	1-1/2	1	310494	2-1/2	1-1/4	4	7/8	1-3/4	1-1/4	310774
2	1-1/4	3-1/2	3/4	1-1/2	1	310496	2-1/2	1-1/2	4	7/8	1-3/4	1-1/4	310775
2	1-1/2	3-1/2	3/4	1-1/2	1	310498	2-1/2	1-3/4	4	7/8	1-3/4	1-1/4	310776
2	1-3/4	3-1/2	3/4	1-1/2	1	310500	2-1/2	2	4	7/8	1-3/4	1-1/4	310777
<b>8 Piece Set – 1/2" to 1-3/4"</b>						<b>300882</b>	<b>10 Piece Set – 1/2" to 2-1/4"</b>						<b>300883</b>
2-1/2	1/2	4	7/8	1-3/4	1-1/4	310769							
2-1/2	5/8	4	7/8	1-3/4	1-1/4	310770							

### Type Z

- Z bushings have a long slot and two set screws in the bushing head
- Provides improved rigidity and reduced chatter



D Outside Diameter (Inch)	d Inside Diameter (Inch)	L Length Under Head (Inch)	C Slot Length (Inch)	E (Inch)	Code	D Outside Diameter (Inch)	d Inside Diameter (Inch)	L Length Under Head (Inch)	C Slot Length (Inch)	E (Inch)	Code		
1-1/4	3/8	3	2-5/8	5/8	310808	<b>7 Piece Set – 3/8" to 1-1/4"</b>						<b>300888</b>	
1-1/4	1/2	3	2-5/8	5/8	310809	1-3/4	1/2	3-1/4	3-1/8	3/4	310821		
1-1/4	5/8	3	2-5/8	5/8	310810	1-3/4	5/8	3-1/4	3-1/8	3/4	310822		
1-1/4	3/4	3	2-5/8	5/8	310811	1-3/4	3/4	3-1/4	3-1/8	3/4	310823		
1-1/4	7/8	3	2-5/8	5/8	310812	1-3/4	1	3-1/4	3-1/8	3/4	310824		
1-1/4	1	3	2-5/8	5/8	310813	1-3/4	1-1/4	3-1/4	3-1/8	3/4	310825		
<b>6 Piece Set – 3/8" to 1"</b>						<b>300887</b>	<b>5 Piece Set – 1/2" to 1-1/4"</b>						<b>300889</b>
1-1/2	3/8	3-1/4	2-7/8	3/4	310814	2	1/2	3-3/4	3-1/2	3/4	310826		
1-1/2	1/2	3-1/4	2-7/8	3/4	310815	2	3/4	3-3/4	3-1/2	3/4	310827		
1-1/2	5/8	3-1/4	2-7/8	3/4	310816	2	7/8	3-3/4	3-1/2	3/4	310828		
1-1/2	3/4	3-1/4	2-7/8	3/4	310817	2	1	3-3/4	3-1/2	3/4	310829		
1-1/2	7/8	3-1/4	2-7/8	3/4	310818	2	1-1/4	3-3/4	3-1/2	3/4	310830		
1-1/2	1	3-1/4	2-7/8	3/4	310819	2	1-1/2	3-3/4	3-1/2	3/4	310831		
1-1/2	1-1/4	3-1/4	2-7/8	3/4	310820	<b>6 Piece Set – 1/2" to 1-1/2"</b>						<b>300890</b>	